

User Manual



Model: RRURF

Wireless Relay Unit with 10 year 3V Lithium Battery Backup and Conduit Adaption



SPECIFICATION

Product Life:	10 years
Supply Voltage:	230V AC
Backup Battery:	3V Lithium Battery (Sealed)
Battery Consumption:	0.8W (standby)
Relay Rating:	250V a.c., 5A resistive
Output:	Continuous or Pulse mode
Visual Indicator:	Two volt free contact (NO/NC)
	Green - Bright: Power On
	Red - Flashing: Low Battery
	Red - Illuminated: RF Pairing Mode
	Red - Illuminated: Fire Triggered
Wireless Interconnection:	
	Radio Frequency [433MHz]
	Wireless Interconnected up to 20 Pieces
	Indoor max 30m / outdoor max 100m
Hardwire Interconnection:	
	Hard Wired Interconnected up to 40 Pieces
	150M in Free Field
Operating/Storage Temperature:	0°C to 45°C
Operating/Storage Humidity:	5% to 95% Relative Humidity
Plastic Material:	ABS
Approval:	AS/NZS 62368.1:2022
	AS/NZS 4268:2017 AMD 1:2021
	AS/NZS CISPR 32:2015 AMD 1:2020

INTRODUCTION

Please read and retain this manual for the entire lifespan of the device, as it contains essential information on the installation and operation of the RRURF Relay Unit with RF. This manual is an integral part of the product. If you are installing the device, you must provide a copy of the manual to the homeowner and any subsequent users.

The RRURF Relay Unit with RF is a highly versatile device that can connect to smoke alarms via both wireless RF signals and hardwired connections. It activates a relay upon receiving an alarm signal from a compatible smoke alarm.

The electrically isolated relay contacts can be utilised for various applications, such as signaling and controlling lights. The RRURF Relay Unit with RF is powered by a 230V AC mains supply and includes a backup battery to ensure continuous operation. By default, the relay is set to operate continuously, switching on when a smoke alarm detects fire and switching off when the alarm condition ceases.

IMPORTANT SAFETY NOTES

- The installation of the RRURF Relay Unit with RF must be performed by a qualified electrician in compliance with relevant local Electrical Installation Regulations. Improper installation may pose risks of electric shock or fire hazards and can damage the product. This unit is not waterproof and should not be exposed to dripping or splashing.
- Connect the RRURF Relay Unit with RF to Alternative Energy Sources (Wind, Solar, UPS, etc.) - This product is designed to connect to a Pure or True Sine Wave 230V AC supply. If you intend to connect it to a power source utilising an inverter, such as a PV solar panel, ensure that the Total Harmonic Distortion (THD) is less than 5%. If you are uncertain about the THD specifications, please consult the inverter manufacturer. The same requirement applies to battery-powered Uninterruptible Power Supply (UPS) inverters.
- The relay base must not be powered from a light dimmer circuit.

INSTALLATION INSTRUCTION

1. BEFORE THE WIRING OF THE RELAY UNIT

NOTE: USERS ARE STRONGLY ADVISED TO READ THE MANUAL THOROUGHLY AND FOLLOW THE STEPS IN CHRONOLOGICAL ORDER TO ENSURE THE PROPER SETUP OF THE RELAY UNIT.

1.1 Ensure the mains power is disconnected from the circuit and the backup battery is turned off before installing the relay unit to ensure safety

1.2 Securely attach the relay unit to the ceiling or wall according to the installation instructions to prevent injury. Select an appropriate mounting position near the mains supply and the device to be connected to the relay.

Note: Avoid metal surfaces or large metal objects that may interfere with the RF signal range.

1.3 If the incoming wiring is on the surface of the wall/ceiling, use appropriately sized conduit to connect with the unit. Carefully remove the knockout material with a sharp knife, ensuring no gaps remain when mated with the conduit.

Note: There is one suitable surface cabling knockout. The other two surface entries are not recommended, as the wiring may reduce the antenna signal. There is one rear entry knockout. Refer to Fig.2 for details.

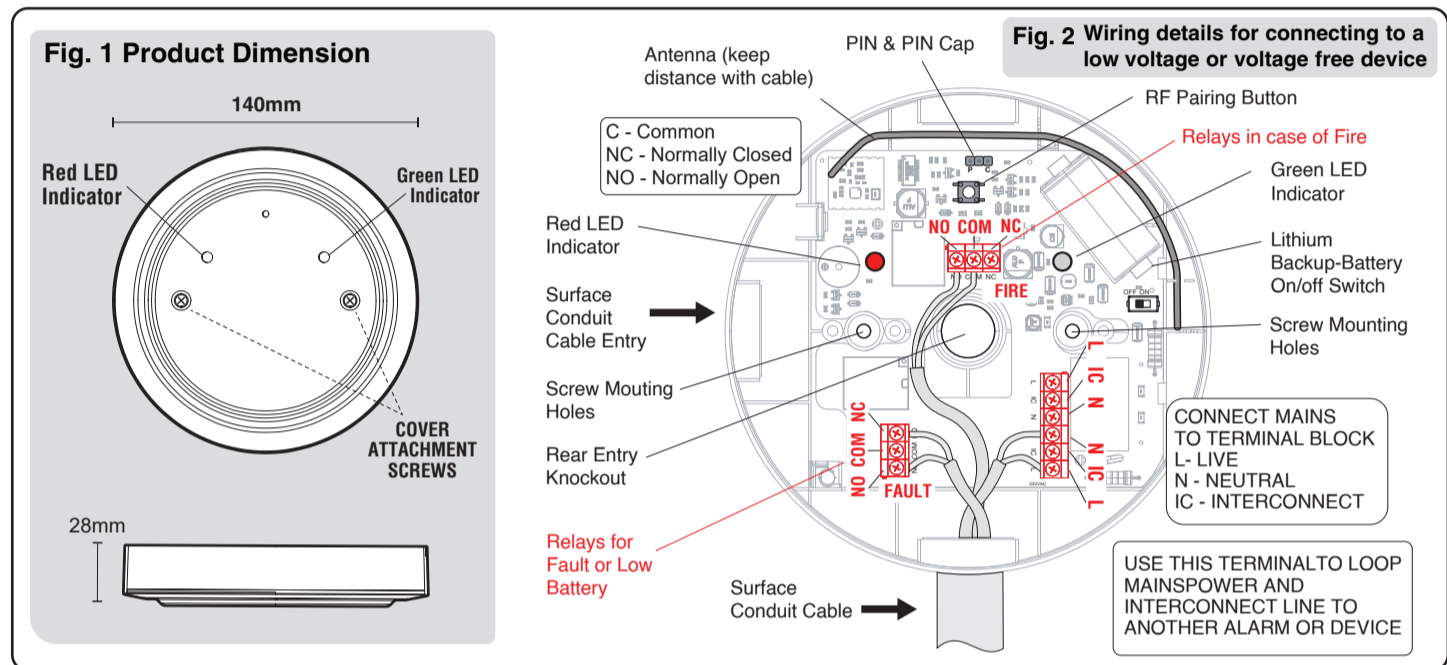

2. INSTRUCTION FOR WIRING

Ensure that the Relay Unit is securely mounted on the wall or ceiling, with house wires passing through it at this stage.

2.1 Connect the power supply wires (Live and Neutral) to the mains terminal block as illustrated in Fig. 2. (Tighten screws to a maximum torque of 0.5 Nm (5.1 kgf.cm)).

There are two relays in this RF base:

The relay terminal marked "FIRE" activates when the Relay Unit receives either a fire warning signal or a test/silence RF signal from the alarm device within the RF network, or a wired connection signal.

The relay terminal marked "FAULT" triggers when the Relay Unit receives a low battery or fault signal from the alarm device within the RF network.

Note: The "FIRE" and "FAULT" relays are independent of each other.

Note: Note: Please refrain from connecting a green/yellow or copper earth wire to any terminal, as grounding the unit is not permitted.

2.2 Connect the L (Live) wire from the auxiliary device power supply to the COM (Common) terminal.

2.3 Depending on the control requirements of the auxiliary device, connect either the NC or NO contact of the relay to the auxiliary device.

• If the relay is used to interrupt a boiler during an alarm, use NC. (refer to Fig. 4)

• For a beacon that should only activate during an alarm, use NO. (refer to Fig. 5)

• Identify the type of auxiliary device and connect it to the "FAULT" relay terminal (refer to Fig. 7 and 8).

2.4 Alternatively, if the auxiliary device shares the same power source circuit as the relay (i.e., 230VAC), insert a linking wire between the L (Live) terminal and the C (Common) terminal of the relay unit. Then, connect the NC or NO contact of the relay unit, depending on the requirement, to the auxiliary device. Connect the N (Neutral) terminal from the relay to the auxiliary device as depicted in the diagrams below. (refer to Fig. 6)

Note: Note: The same wiring method can also be applied to the "FAULT" Relay Terminal. (refer to Fig. 9).

APPLICATION OF TRIGGERING THE RELAY, IN CASE OF FIRE ALARM

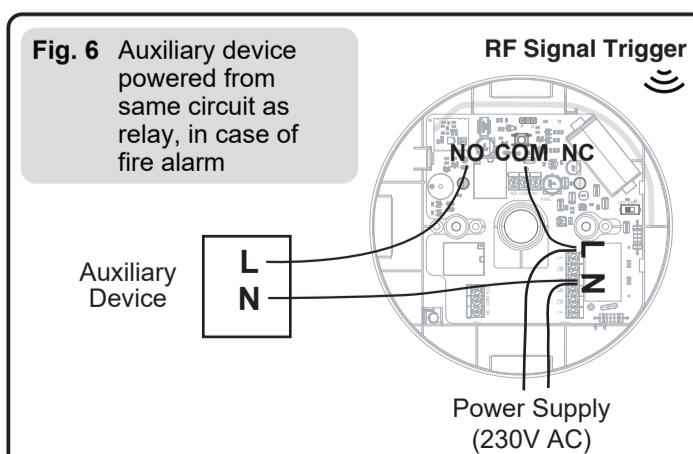
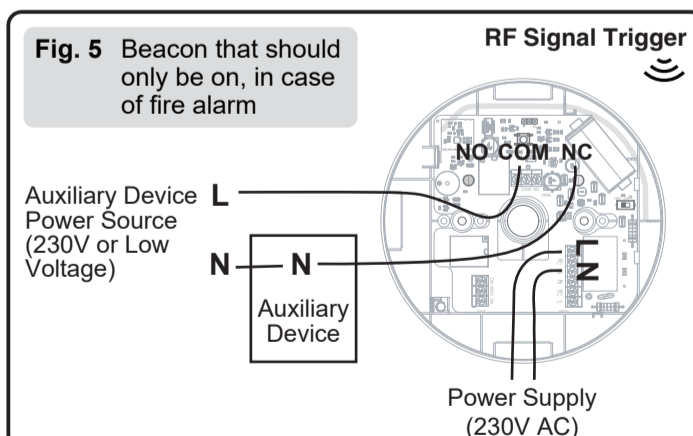
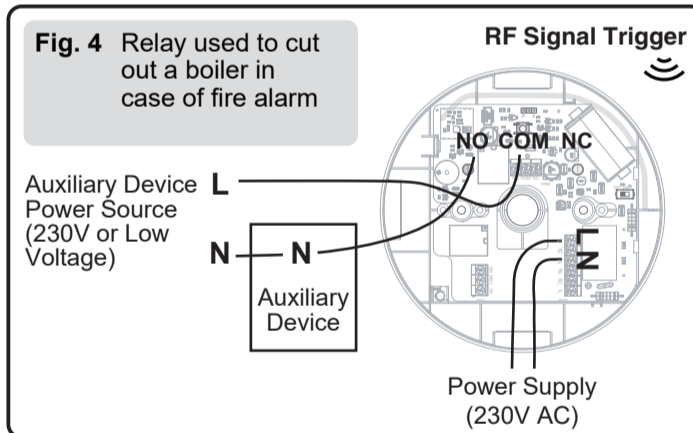

APPLICATION OF TRIGGERING THE RELAY, IN CASE OF LOW BATTERY OR FAULT

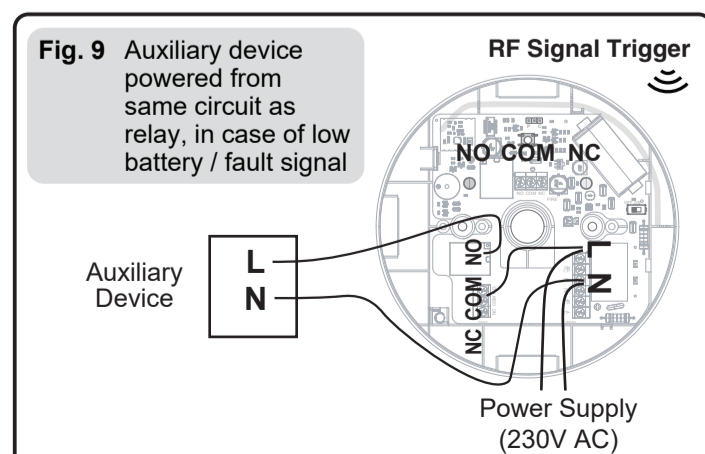
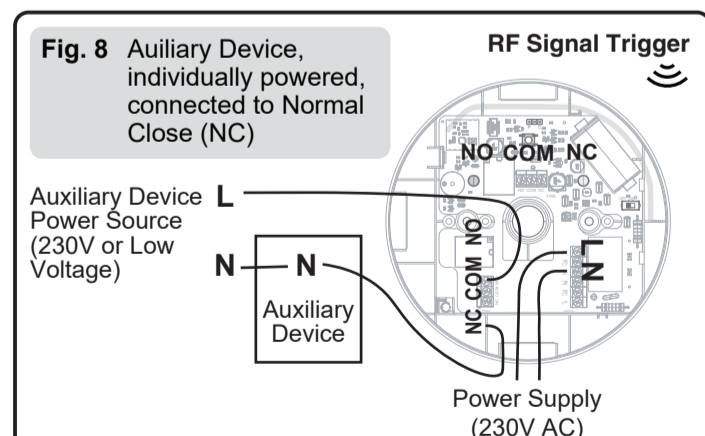
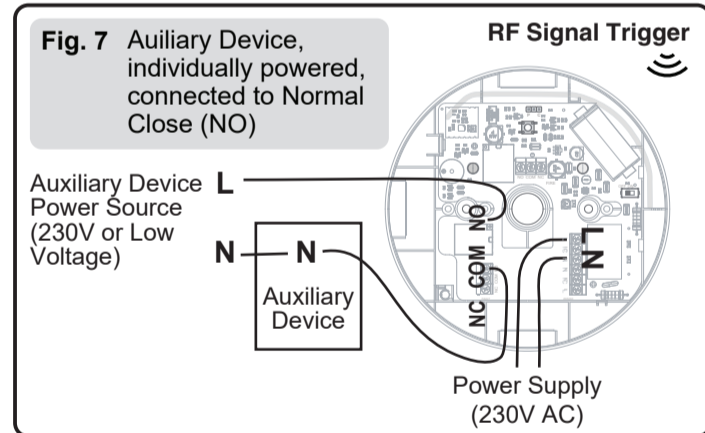

3. CONFIGURE THE RELAY OPERATION TO EITHER CONTINUOUS OR PULSE MODE. (APPLIES ONLY TO THE FIRE RELAY.)

3.1 To configure the relay for continuous or pulse operation, locate the PIN cap and the 3 PINs.

By default, a black pin cap should be installed on 2 pins on the right side, indicating continuous operation where the relay switches on when a smoke alarm detects fire and switches off when the alarm condition ends.

3.2 For momentary (pulse) relay operation, carefully remove the black pin cap and place it in the "P" position (refer to Fig. 10).

In the "P" position: Upon receiving a signal, the relay unit will activate the relay for 5 seconds.

This configuration is typically used in warden call systems that require momentary short-circuit signaling. Perform this setup before connecting the mains power or activating the battery.

3.3 With the switch set to the "C" (Continuous) position, the alarm signal will engage the latching relay until a cancel signal is received.

When set to the "C" position: Upon receiving a fire signal, the relay unit will activate the relay until a cancel signal is received.

Note: The "FIRE" Relay Terminal and "FAULT" Relay Terminal are separate features. The option to switch between "Continuous or Pulse" operation applies exclusively to the "FIRE" Relay Terminal.

Note: The PIN Cap at the operation setting does not affect the "FAULT" Relay Terminal.

Note: The "FAULT" Relay Terminal operates exclusively in "Continuous" signal mode.

4. ACTIVATE THE LITHIUM BATTERY STATUS FROM "OFF" TO "ON".

4.1 Activate the battery by sliding the switch to the "ON" position (refer to Fig. 2). Ensure the switch is in the 'ON' position for proper operation.

4.2 Attach the cover and secure it in place using the provided screws.

5. VERIFY THE RELAY UNIT POWER SUPPLY.

5.1 Apply mains power to activate the RRURF Relay Base.

5.2 Ensure the green indicator light is illuminated upon applying mains power. If the green light is not illuminated, first disconnect the mains power. Then, carefully remove the plastic cover and verify the accuracy of the wiring connections.

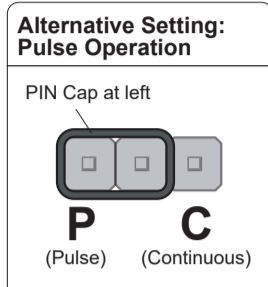
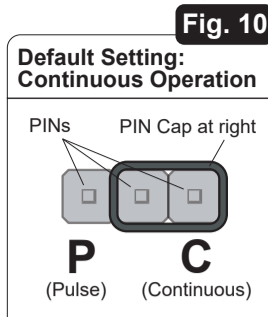

Note: The green LED indicates the presence of AC power. Turn ON the backup battery to ensure proper operation.

6. RF WIRELESS PAIRING INSTRUCTION

6.1 RF WIRELESS PAIRING

Locate the RF Pairing Button on the RF Relay Unit.

- RRURF as Master
Locate the RF Pairing Button on the RF Relay Unit.
– Use a pin to press and hold the pairing button for 10 seconds until the red LED illuminates, the red LED will remain on for 150 seconds.
- RRURF as Slave
– Use a pin to press the pairing button 2 times, the red LED will flash for 5 times to indicate successfully connection

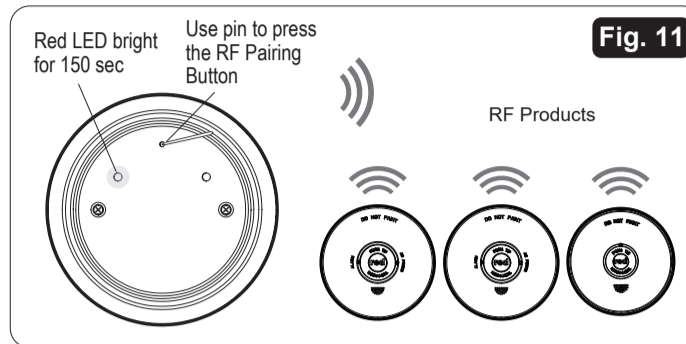

- To exit RF pairing mode, press the RF pairing button once. The red LED will turn off.

- The RRURF Relay Unit will automatically exit RF pairing mode after 150 seconds. The Red LED indicator will turn off, and the system will return to standby mode.

Note: If certain devices continue to flash red, refer to their instruction manual for manual exit from RF pairing mode. Ensure that RF indicators have ceased flashing on all devices.

Note: Once the RF network is established, the system will exclusively communicate within the RF paired group and not with any other RF alarms or devices outside this group.

Clear Pairing Memory

- Press the RF pairing button 5 times, the red LED on the alarm will flash 10 times.

6.2 TEST THE RF PAIRING NETWORK

To verify the RF network, press the Test button on any RF Paired Alarm for up to 5 seconds. After a brief moment, all alarms should activate. Confirm that the device connected to the relay contacts operates as intended. Release the test button after 60 seconds and ensure the device deactivates. If the slide switch is set to pulse mode, verify that the relay activates for 5 seconds and then deactivates. Repeat this process for all RF devices within the network.

Note: The "FIRE" relay feature can be tested by pressing the Test/Hush button on an alarm device within the RF network. However, to activate the "FAULT" feature, the RF Relay base must receive a low battery or fault signal from alarm devices within the RF range. Therefore, testing the "FAULT" feature from the default setting is not possible. For assistance with testing the "FAULT" relay feature, please contact Red Smoke Alarms for further guidance.

Note: Up to 20 RF devices can be interconnected to a single relay. When one alarm triggers, all interconnected alarms will activate, and the relay will switch accordingly.

CHECKING & MAINTENANCE

1. PERFORMANCE CHECK INSTRUCTIONS

We recommend that end-users perform a monthly RF network check on this device. Please follow the steps below:

(1) Verify if the green LED power indicator is illuminated. If not, inspect the circuit breaker, fuse, and wiring. Once mains power is restored, the green indicator will remain steady.

(2) If the red LED flashes once every 10 seconds, indicating a battery issue with the relay unit:

Ensure the battery power switch is in the "ON" position. If not, switch it to "ON", allow the battery to optimise's power circulation for 2 hours before rechecking.

If the unit continues to flash red every 10 seconds, it may be defective and requires replacement. Refer to the "WARRANTY" section.

(3) Press the Alarm Test Button and verify:

- The relay switches.
- The auxiliary device functions as expected.

2. BACKUP BATTERY STATUS

To ensure the RRURF functions correctly, it is essential to periodically check the status of its backup battery. We recommend end-users perform this Backup Battery Status Check immediately after installation and at least once a year.

- Disconnect the mains supply.
- Follow the steps outlined in "PERFORMANCE CHECK INSTRUCTIONS" to verify the relay.
- If everything functions correctly, reconnect the mains power.
- If the relay fail to operate, the unit is defective and requires replacement.

END OF LIFE

After 10 years (refer to the date label on the side of the Relay), the RRURF Relay Base should be replaced.

TROUBLESHOOTING RF PAIRING

If the RRURF does not respond during testing, follow these steps:

- Ensure the RF Pairing Button is held down until the RF light illuminates, which may take up to 10 seconds.
- If the issue persists, reset the RF pairing by pressing the RF Pairing button 5 times. The LED will flash red 10 times, indicating that the RF memory has been cleared and the RRURF is reset. Refer to the instruction manuals of other devices in the system to reset them accordingly. Once all devices are reset, repeat the RF pairing procedure.
- If resetting the RF pairing does not improve signal reception, consider relocating the RRURF and/or adjusting the placement of alarms. Changing the position of alarms can significantly enhance signal reception, but this may also lead to some devices being out of range of previously paired devices. Therefore, ensure all

detectors/relays communicate effectively in their final installed positions. If units are relocated or adjusted, it is recommended to reset the RF pairing at the final positions. Finally, test the RF pairing to ensure the issue is resolved.

LIMITATIONS OF THE RF PAIRING

While the RRURF RF Pairing system is highly reliable and tested to rigorous standards, it operates within certain limitations due to its low transmitting power and restricted range as mandated by regulatory bodies. Here are important considerations:

Receivers may experience blockages from radio signals operating on or near their frequencies, irrespective of RF Pairing.

Regular testing of RF systems is recommended, ideally on a monthly basis. This ensures detection of potential interference sources that may disrupt communication paths, such as moving furniture or renovations, and provides early warning of faults and other issues.

INDICATION AND ACTION

If you observe any indication from the RRURF Relay Unit and are uncertain about its condition, please refer to the table below for the "LED Indicator" and "Siren". The table will help you determine the current status of the patress and the appropriate action to be taken. If you require further assistance, we recommend reaching out to our technical support for inquiries. You can find the contact details in this manual.

Status	Green LED Indicator	Red LED Indicator	Siren	Action Needed
Standby Mode (Battery Power Only)	Off	Off	Off	Connect the Relay Unit to AC main power to complete the installation.
Standby Mode (240V AC Mains Power)	Illuminated (when AC power is connected)	Off	Off	None.
RF Fire Warning Signal, PIN Cap in "P"	Illuminated (when AC power is connected)	Illuminated until fire signal ceases	Off	An alarm in the RF network has emitted a test or fire signal. The "FIRE" relay is triggered for 5 seconds, then returns to normal status.
RF Fire Warning Signal, PIN Cap in "C"	Illuminated (when AC power is connected)	Illuminated until fire signal ceases	Off	An alarm in the RF network has emitted a test or fire signal. The "FIRE" relay is triggered until the device in the RF network sends a "cancelled" signal.
Hardwire Fire Warning Signal, PIN Cap in "P"	Illuminated (when AC power is connected)	Illuminated until fire signal ceases	Off	A hardwired interconnected alarm has emitted a test or fire signal. The "FIRE" relay is triggered for 5 seconds, then returns to normal status."
Hardwire Fire Warning Signal, PIN Cap in "C"	Illuminated (when AC power is connected)	Illuminated until fire signal ceases	Off	A hardwired interconnected alarm has emitted a test or fire signal. The "FIRE" relay is triggered until the device in the RF network sends a 'cancelled' signal.
RF Fault Warning Signal (Low Battery or Fault Warning Received in RF Network)	Illuminated (when AC power is connected)	Off	Off	An alarm in the RF network has a low battery or fault. The "FAULT" relay is triggered. 1. Press the RF Pairing button to reset the relay. 2. The RF device in the network has been reset. The Relay Unit will no longer receive the RF signal and will reset to normal status in 5 hours. Refer to Section "INSTALLATION INSTRUCTION 6. RF WIRELESS PAIRING INSTRUCTION" for further details.
Relay Unit Low Battery Signal	Illuminated (when AC power is connected)	Flashes once every 10 seconds	Chirps every 10 seconds	Replace the Relay Unit.
RF Pairing Mode Activated (Master Mode)	Illuminated (when AC power is connected)	Illuminated for 150 seconds	Off	The Relay Unit has been activated as the master in the RF network. Ensure other alarm devices in the RF network join within this period. After 150 seconds, RF Pairing mode will automatically turn off.
Joining the RF Pairing Network	Illuminated (when AC power is connected)	Flashes twice as indication	Off	Press the RF Pairing button on the Relay Unit twice to join the RF network.

WARRANTY

Red Smoke Alarms warrants the RRURF to be free from defects in materials and workmanships under normal use and service for a period of ten years from manufacture date. The company will not be obligated to repair or replace parts which are found to be in need of repair because of misuse, damage or alterations that occur after the date of purchase. Return the RRURF Relay Base with proof of purchase to your local distributor. The liability of the company arising from the sale of this RRURF Relay Base shall not in any case exceed the cost of replacement and in no case shall the company be liable for consequential loss or damages resulting from the failure of the RRURF Relay Base.

RED SMOKE ALARMS PTY. SHALL HAVE NO LIABILITY FOR ANY PERSONAL INJURY OR PROPERTY DAMAGE, OR ANY SPECIAL INCIDENTAL, CONTINGENT OR CONSEQUENTIAL DAMAGE OF ANY KIND RESULTING FROM A FIRE. THE EXCLUSIVE REMEDY FOR BREACH OF THE LIMITED WARRANTY CONTAINED HEREIN IS THE REPAIR OR REPLACEMENT OF THE DEFECTIVE PRODUCT AT RED SMOKE ALARMS PTY. LTD. OPTION. IN NO CASE SHALL RED SMOKE ALARMS PTY. LTD.'S LIABILITY UNDER ANY OTHER REMEDY PRESCRIBED BY LAW EXCEED THE PURCHASE PRICE. YOUR RRURF RELAY BASE IS NOT A SUBSTITUTE FOR PROPERTY, DISABILITY, LIFE OR OTHER INSURANCE OF ANY KIND. APPROPRIATE COVERAGE IS YOUR RESPONSIBILITY. CONSULT YOUR INSURANCE AGENT.

This does not affect your statutory rights.

This device is only suitable for single occupancy private dwellings only and not intended for multi occupancy private dwellings or commercial or industrial dwellings.

Waste electrical products should not be disposed of with normal household waste. Please recycle where facilities exist. Check with your Local Authority or retailer for recycling advice. New regulation will encourage the recycling of Waste from Electrical and Electronic Equipment (European "WEEE Directive" effective August 2005).

Red Smoke Alarms PTY. LTD. reserves the right to change specifications, - modify designs and discontinue items without incurring obligation and whilst every effort is made to ensure that descriptions, specifications and other information in this catalogue are correct, no warranty is given in respect of these of and the company shall not be liable for any error therein.

© Red Smoke Alarms 2024

This material copyright under Australian and international laws. Except as permitted under the relevant law, no part of this work may be reproduced by any process without prior written permission of and acknowledgment to Red Smoke Alarm PTY. LTD..

Contact Details

RED SMOKE ALARMS PTY. LTD.
35 Hitech Drive, Kunda Park QLD 4556
service@redsmokealarms.com.au
www.redsmokealarms.com.au
1300 316 552
E&OE
V1.0

