

Choosing the correct surge protection equipment.



An easy to use guide for contractors.

Surge protection made easy

We invest thousands of dollars in state-of-the-art electronic equipment and insure it against theft and damage. But when it comes to protection against damage caused by overvoltage surges we're sometimes unaware of what is available.

The causes of surges are many and varied. By far the most common cause is through switching operations in the network. Surge damage caused by lightning strikes also occurs frequently. Computers are one of the most relied on tools of the trade and the information stored in them can be irreplaceable if lost. Fax machines, photocopiers and valuable printing equipment all need protection from the hazards of lightning strikes. Overvoltage peaks lasting only some millionths of a second, can cause the failure of a semiconductor module and destroy the whole system. Protection is gained by connecting all possible conductive paths to earth at the instant the overvoltage appears within the installation and thereby breaking up the otherwise harmful surge. It can be difficult to know which parameters are important when selecting surge protection equipment. The following information has been prepared to help you.

The Safe Protection Concept

Test Wave Forms

Test wave forms are used to emulate real life transients from which surge protection devices are designed. Below in yellow shows the transient a spark gap product must endure during a direct lightning strike. Below in green shows the transient a varistor must endure during a switching transient or an indirect lightning strike.

Power Range Arresters

As a first protective measure, a barrier is necessary to keep the lightning current out of the system.

Spark Gaps respond to the lightning current impulse of 10/350 μ S at the required level and break it to a current impulse of 8/20 μ S tolerable for subsequent Surge Protection Devices.

When using Spark Gaps in the power supply system, the mains follow on current must be safely extinguished after discharging a current impulse.

As a second protective measure, the remaining current impulse (approx. 8/20 μ S) is discharged and limited to a voltage level compatible with the system.

A varistor (non-linear resistor) is ideal for this task. Modern metal oxide varistors are distinguished by their fast response time and low residual voltage (voltage protection level).

What does 20kA (8/20 μ S) mean?

20kA is the impulse current. 8/20 μ S. The first value (8) is the rise time (from 10% to 90% of peak). The second value (20) is the duration for the test transient to decrease to half its peak value.

Lightning Protection Zone Concept

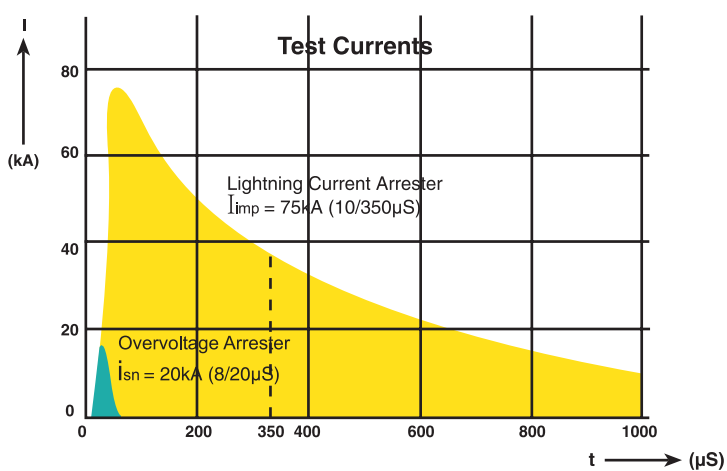

Surge Protection Devices

Electrical equipment will be vulnerable if exposed to voltages greater than 1.5kV, particularly with sensitive electronic equipment at voltages greater than 800V.

Clipsal Surge Protection Devices work to reduce overvoltages to figures less than 800V.

To do this most effectively, there are three methods of combating the likelihood of this danger to equipment occurring.

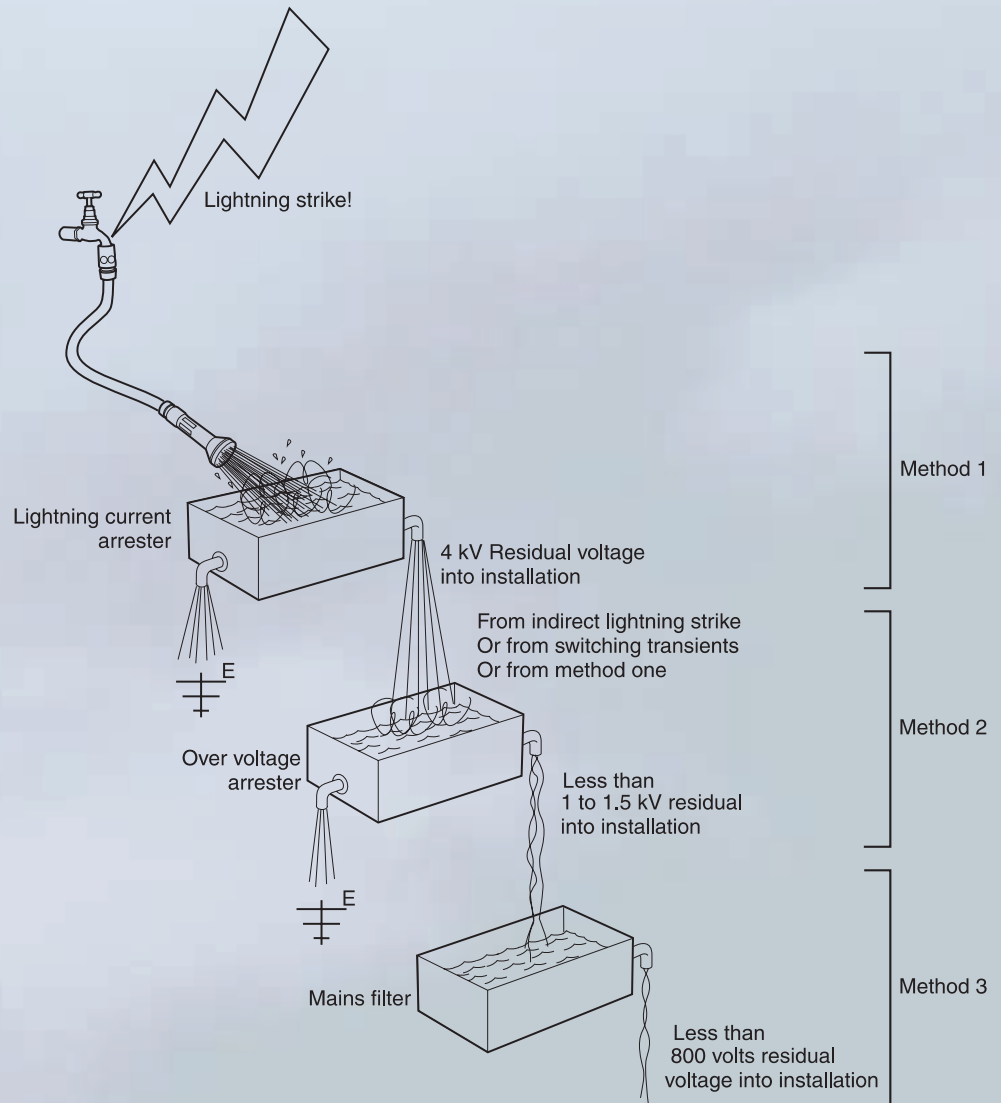

Method of Protection

Method 1 (Lightning Current)

Spark Gap Arresters are heavy-duty devices that work on a similar principle to a car spark plug. (i.e., when energy is large enough it jumps the gap to earth.)

These devices can handle high currents similar to direct lightning strikes, however leave a relative high residual voltage less than 4kV. (Not suitable for equipment protection, but reduces energy to a manageable level.)

Method 2 (Overvoltage)

The most common and inexpensive first line of defence against a power surge is a Metal Oxide Varistor (MOV).

Clipsal Overvoltage Arresters have a discharge capacity of 20kA (8/20 μ S). The component that protects electrical equipment from overvoltages will withstand this current impulse at least 20 times, non destructively and without changes to its characteristic.

These devices will give voltage protection less than 1 to 1.5kV (8/20 μ S), and are used in locations that are exposed to indirect lightning strikes and switching transients.

Method 3 (Overvoltage Filtering)

Mains Filters provide additional overvoltage protection to protect sensitive electronic equipment.

The Clipsal Mains Filters are used in conjunction with overvoltage protection by providing additional filtering to slow down the rate of rise of voltage spill and reduce let through voltage to less than 800V.

Methods of Protection

Low risk protection, methods 2 and 3 discussed on page 3 suit installations vulnerable due to switching transients and indirect lightning strikes. As a guide indirect lightning strikes 1.5 kilometres away can generate surge voltage into the kilovolt range which can be protected by this method. Below are schematics of typical installation methods.

Low Risk Protection

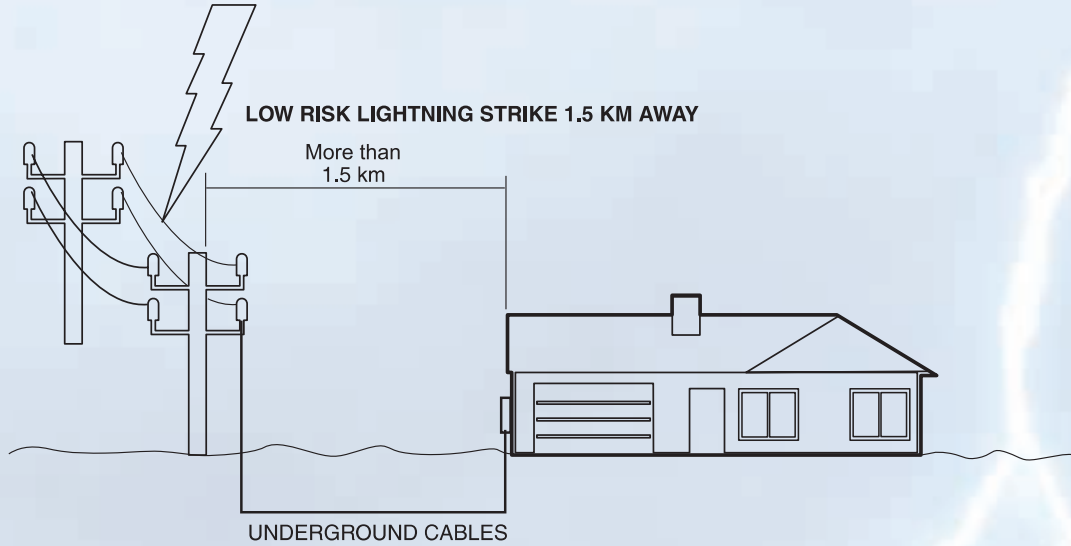

Low Risk Medium Protection

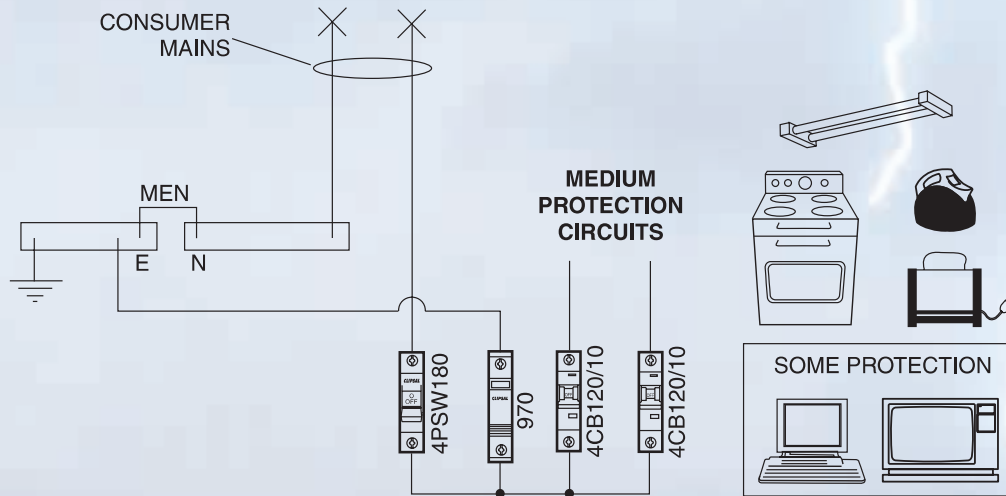

Low Risk Fine Protection

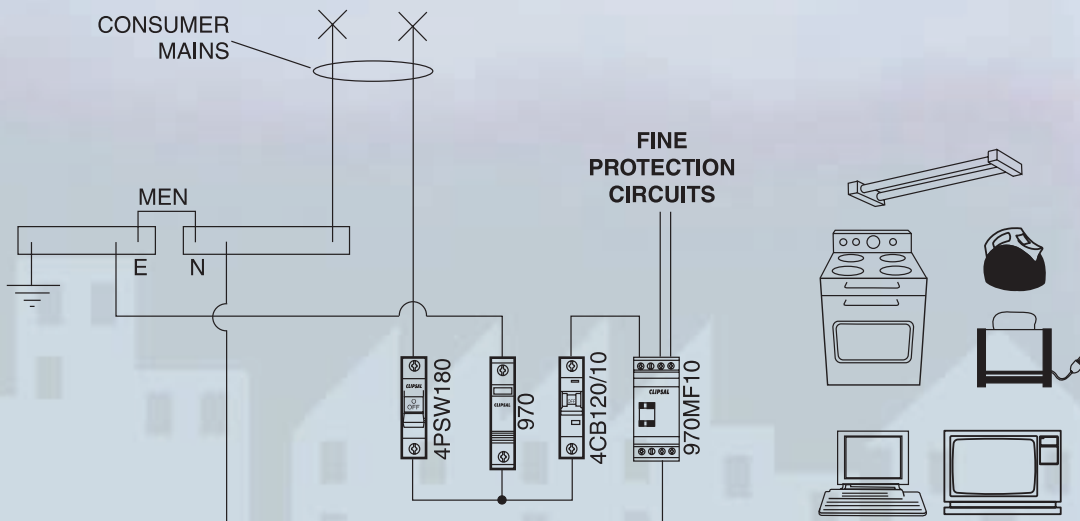

Methods of Protection

High risk protection methods 1, 2 and 3 discussed on page 3 suit installations that could receive direct lightning strikes. This type of installation provides enhanced protection and customer peace of mind.

High Risk Protection



High Risk Medium Protection

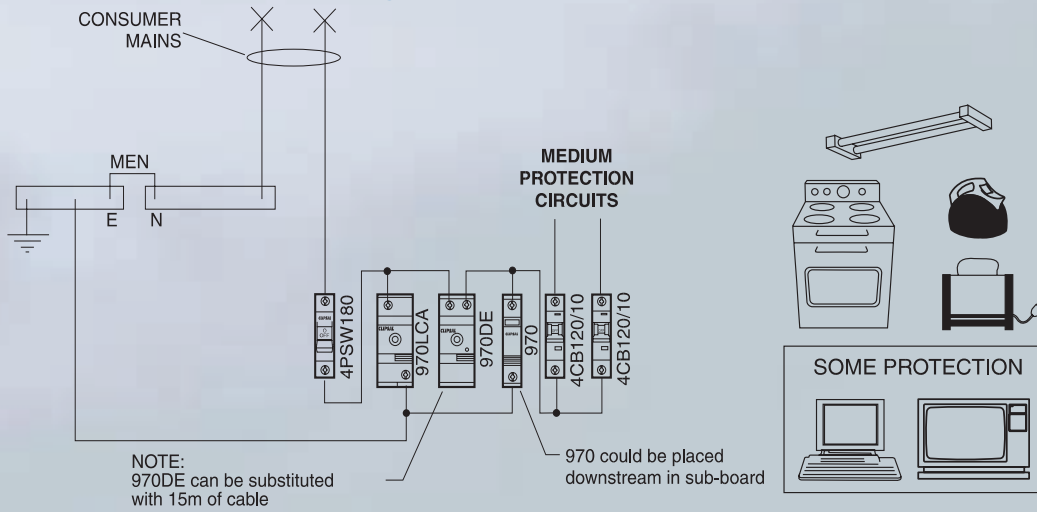

High Risk Fine Protection

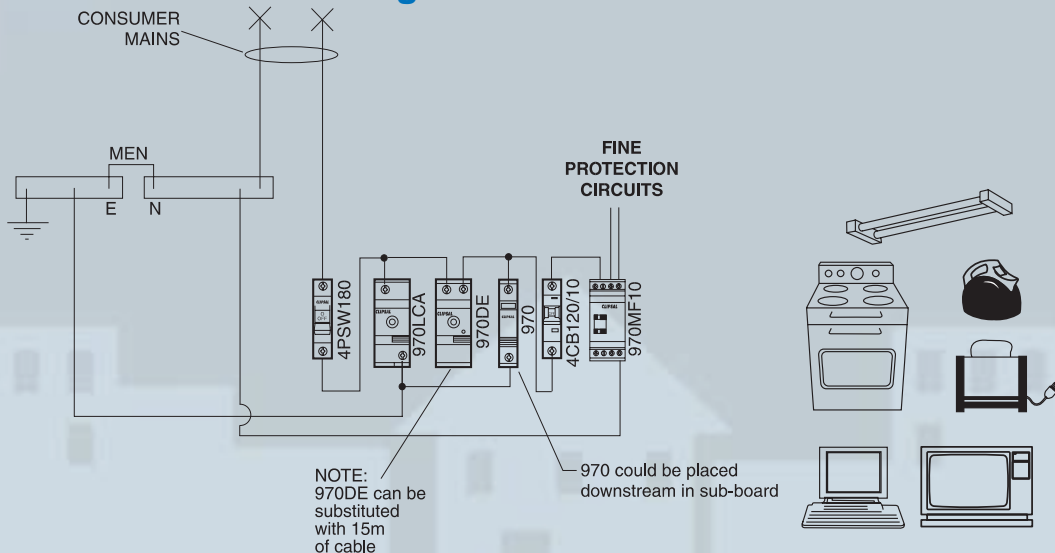

▪ Note - Fault current limiting pre-fuse not shown

Power range surge arresters



950/4

950/4 High Capacity 4 Pole Arrester

- Combined overvoltage and current arrester (spark gap, inductor and metal oxide varistor)
- DIN mounted 6.5 modules wide
- Surge current 65kA (4/10) 4 pole
- Maximum pre-fuse 100A gl

Benefits

- Fast and easy installation
- Provides lightning current and overvoltage protection (lightning protection)

Limitations

- Visual indication when overloaded and replacement required
- Must replace whole unit (higher material cost)
- Care taken during installation due to blow out path



970RMT

970 Overvoltage Arrester (Metal Oxide Varistor)

- 275V, 20kA 1 pole DIN 1 module wide
- Maximum pre-fuse 125A gl
- First line of protection against overvoltages

Benefits

- Fast and easy installation
- Provides overvoltage protection

Limitations

- Does not protect from a direct lightning strike
- Visual indication when overloaded and replacement required
- Must disconnect wiring to remove



970



970LCA

970RM Overvoltage Arrester (Metal Oxide Varistor)

- 275V, 20kA 1 pole DIN 1 module wide
- Maximum pre-fuse 125A gl
- First line of protection against overvoltages

Benefits

- Fast and easy installation
- Provides overvoltage protection
- Removable modules allow quick replacement without the need to disconnect wiring

Limitations

- Does not protect against a direct lightning strike
- Visual indication when overloaded and replacement required



970RM



970/3LCA

970RMT Overvoltage Arrester

- As for 970RM with the added advantage of auxiliary contacts that can be used to alert when 970 module requires replacement.



970DE

970LCA Lightning Current Arrester (Spark Gap)

- 264V, 25kA, 1 pole DIN 2 module wide
- Maximum pre-fuse 100A gl
- For increased protection against direct lightning strikes

Benefits

- Provides protection against direct lightning strikes
- Fully encapsulated no blow out path
- Never requires replacing

Limitations

- Must be used with decoupling element 970DE (or 15 metre length of cable) and 970 Overvoltage Arrester. (Refer to the diagrams on page 4 & 5.)



463SF



2025SF

970/3LCA Lightning Current Arrester (Spark Gap)

- 264V, 25/75kA, 3 pole DIN 4 module wide
- Maximum pre-fuse 100A gl
- For increased protection against direct lightning strikes

Benefits

- Provides protection against direct lightning strikes
- Fully encapsulated no blow out path
- Never requires replacing

Limitations

- Must be used with decoupling element 970DE (or 15 metre length of cable) and 970 Overvoltage Arrester. (Refer to the diagrams on page 4 & 5.)



970MF10

970DE

(Decoupling Element 500V 35A)

970DE63

(Decoupling Element 500V 63A)

- Provides energy coordination between 970LCA Lightning Current Arrester 2 modules wide and 970 Overvoltage Arrester
- The 970DE Series can be substituted with 15 metres of cable

Benefits

- Allows installation of the 970LCA Lightning Current Arrester and the 970 Overvoltage Arrester located side by side in the same switchboard

Limitations

- The 970DE is connected in series with the load and therefore maximum through current is limited to 35 Amps (970DE) or 63 Amps (970DE63)

463SF (Metal Oxide Varistor)

Surge Filter Plug Adaptor

25SF, C2025SF, 2025SF (metal oxide varistor) Socket Outlet

- 250V, 10A
- Power outlet double 250V, 10A - surge protected
- Surge current 6.5kA 8/20μS
- A third protective measure if overvoltage possibility exists between the distribution board and the terminal equipment

Benefits

- Local protection at point of supply to equipment
- Provides overvoltage protection

Limitations

- Low energy absorption 6.5kA 8/20μS
- Visual indication when overloaded and replacement required
- Does not protect from a direct lightning strike

970MF10 / 970MF20 Mains Filter

- 970MF10 - 250V, 10A, 2 module wide
- 970MF20 - 250V, 20A, 4 modules wide
- Work in conjunction with the 970 Overvoltage Arrester by providing additional protection to sensitive electronic equipment

Benefits

- Additional protection provides filtering to slow down the rate of rise of a voltage spike
- Never requires replacing

Limitations

- Additional space required to switchboard
- The 970MF is connected in circuit with the load and therefore maximum through current is limited to 10Amps (970MF10) and 20Amps (970MF20)

Clipsal Overvoltage Protection Equipment

Overvoltage Arresters	
Cat. No.	Description
950/4	High capacity 4 pole overvoltage arrester, DIN mounted
970	Overvoltage arrester, 275V, 20kA
970P	Replacement protection plug, 275V, 20kA
970RM	Overvoltage arrester with removable module, 275V, 20kA
970T	Overvoltage arrester with auxiliary contacts, 275V, 20kA
970RMT	Overvoltage arrester with removable module and aux./cont., 275V, 20kA
970MF10	Mains filter 250V 10A 50/60Hz 2 modules wide
970MF20	Mains filter 250V 20A 50/60Hz 4 modules wide
970DE	Decoupling element, 500V, 35A
970DE63	Decoupling element, 500V, 63A
970LCA	Lightning current arrester, 264V, 25kA
970/3LCA	Lightning current arrester, 264V, 25/75kA – 3 pole
25SF	Power outlet, double, 250V, 10A
463SF	Surge filter plug adaptor, 250V, 10A
C2025SF	Power outlet, double, surge protected
2025SF	Power outlet, double 250V, 10A with surge protection
951	Disconnection spark gap
952	Disconnection spark gap type Ex

Products of Gerard Industries Pty Ltd

ABN 27 007 873 529

Head Office

12 Park Terrace, Bowden
 South Australia 5007
 Telephone (08) 8269 0511
 Facsimile (08) 8340 1724
 Internet clipsal.com
 E-Mail plugin@clipsal.com.au

International Enquiries Head Office Export Department

Telephone +61 8 8269 0587
 Facsimile +61 8 8340 7350
 E-Mail export@clipsal.com.au

Offices in all States

NSW Sydney (02) 9794 9200
 Albury (02) 6041 2377
VIC Melbourne (03) 9207 3200
 Country Areas 1800 653 893
QLD Brisbane (07) 3244 7444
 Townsville (07) 4729 3333
SA Adelaide (08) 8269 0555
WA Perth (08) 9442 4444
TAS Hobart (03) 6272 3177
 Launceston (03) 6343 5900
NT Darwin (08) 8947 0278

New Zealand

Clipsal Industries (NZ) Ltd (Auckland)

Telephone (09) 576 3403
 Facsimile (09) 576 1015
 E-Mail headoffice@clipsal.co.nz

Customer Service

Free Fax (0508) 250 305
 Auckland/Mobile
 Phone (09) 572 0014
 Free Phone (0508) CLIPSAL
 254 7725