

en

CLIPSAL

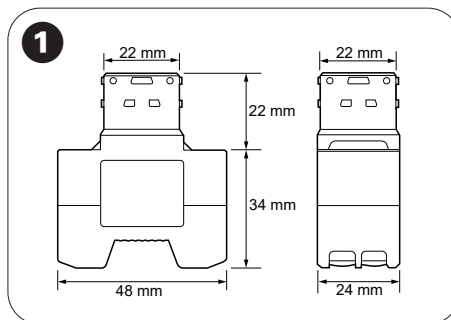

41EPBDWCLMZ-VW  
PDL354PBDMBTZ-VW

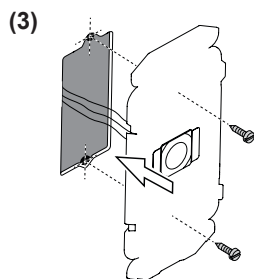
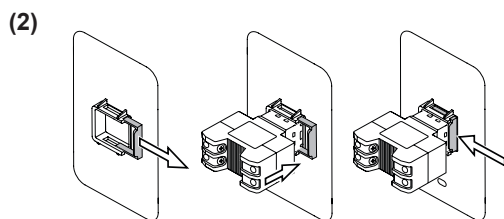
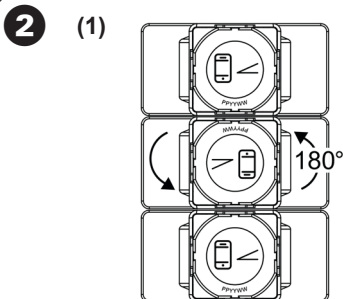

WiZer™

Schneider  
Electric

JYT55070

## en Iconic Connected Dimmer

## About this product

The Iconic Connected Dimmer operates as a dimmer "out-of-the-box", with no configuration needed. The dimmer is available with Zigbee connectivity.

The dimmer can be used as one device in a Wiser Hub network. To do this, the dimmer must be paired to the Wiser Hub via the Wiser Home app.

## 1 Dimension drawing

## Mounting and connection

## ⚠️ DANGER

## HAZARD OF ELECTRIC SHOCK, OR ARC FLASH

- It is illegal for persons other than an appropriately licensed electrical contractors or other persons authorised by legislation to work on the fixed wiring of any electrical installation.
- To comply with all safety standards, the device must be used only for the purpose described in this instruction and must be installed in accordance with the wiring rules and regulation in the location where it is installed.
- Lock out and tag the input circuit before accessing the wiring connections.
- The locking bar on the grids must be set to the closed position to ensure that the device cannot be removed during normal operation.
- There are no user serviceable parts inside the device.

**Failure to follow these instructions will result in death or serious injury.**

## ⚠️ CAUTION

## EQUIPMENT DAMAGE HAZARD

- Install the device according to instructions in this document.
- Pay attention to the specifications and wiring diagrams related to the installation.
- Do not use the device for any other purpose than specified in this instruction.
- Dropping the device may damage the internal components. Check that the device operates after being dropped or if physical damage is shown.

**Failure to follow these instructions can result in minor injury or equipment damage.**

## NOTICE

## EQUIPMENT DAMAGE HAZARD (LOAD AND OPERATION)

- Operation of the device at elevated temperatures or voltages outside of specification (240 V AC and 25 °C) may cause the over-temperature protection circuitry to operate. Operating with significant overload may activate thermal shut-down. In extreme cases, the thermal fuse may blow and render the device inoperable.
- Reduce the size of the connected load or use a different brand of lamp to prevent recurrence.
- Do not operate the product for prolonged periods in extreme conditions.

**Failure to follow these instructions can result in equipment damage.**

## NOTICE

## MAXIMUM LOAD RATINGS APPLY

Ensure that the number of low voltage lighting transformers connected to a single device does not exceed the maximum load rating of the device.

**Failure to follow these instructions can result in equipment damage.**

## 2 Installing the product

- (1) Multi-gang orientation
  - When installing in a 3-gang plate, the middle module must face the opposite way to the other 2 modules.
  - The maximum load rating of each module must be derated (see **Derating** section).
- (2) Fit the module to the grid. Consider the depth of the wall box.
- (3) Mount the grid.

## Wiring and connections

- ControlLink Module
- Connected Dimmer
- Load
- 2-way switch

A = Active

N = Neutral

L = Load

CTL = ControlLink

PE = Protective Earth

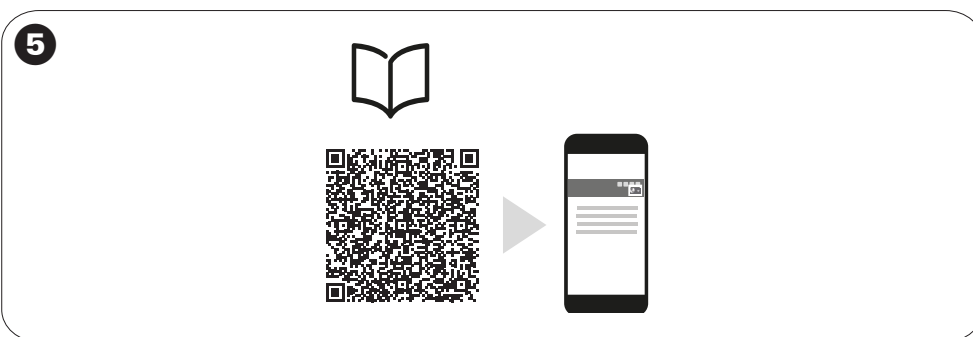
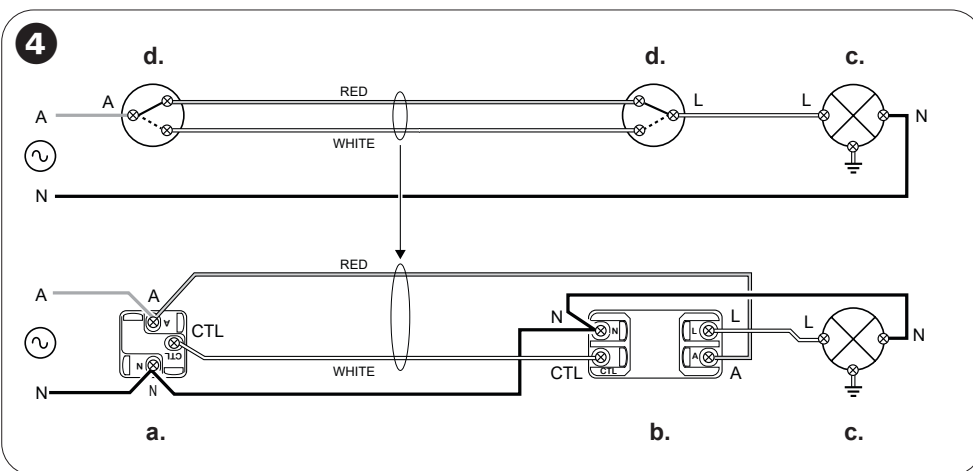
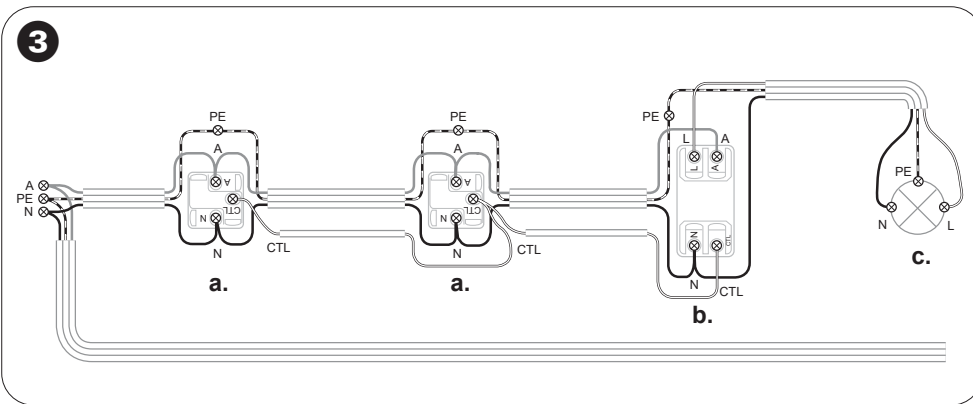

### 3 Typical 3-way installation using Iconic Connected Module

**NOTE:** Set the Controllink Module to Switch mode - see Controllink Module instructions.

#### NOTE:

- All active connections must be on the same phase.
- Up to 5-way dimming (e.g. 1x Dimmer plus up to 4x Controllink Modules, or up to 3x Dimmers plus 2x Controllink Modules).
- In case of multiple dimmers being installed, each dimmer must be connected to a separate load.
- Total length of CTL and Active loop: max. 50 m.
- Control and load cables must not be coupled.

### 4 Retrofit (2-way installation shown)

### 5 Reading the full device user guide online

Scan the QR code for complete information about the device, including operation, configuration and using the product.

#### Technical data

Operating voltage	220 – 240 V AC, 50 Hz	
Load rating	No minimum load required	
	Max. 300 W	
Dimmable LED	0 – 150 W	
Dimmable compact fluorescent 240 V incandescent/halogen LV halogen with electronic transformer	0 – 300 W	
Non-dimmable LED	not compatible	
Non-dimmable compact fluorescent	not compatible	
Load connection	LED indicator flashes in the event of load disconnection or failure	
Dimming range	Min. 0%, Max. 100% (depending on load)	
Protection	Over temperature:	Yes
	Short circuit:	Yes
	Over-current/thermal fuse:	Yes
LED indicator	Yes	
Multiway control	Yes, via Controllink	
Multiway limits	Max. 5-way dimming (Max. 3 Iconic Connected Dimmers + remainder Controllink Modules.)	
Controllink/Active cable limit	Total length of CTL and Active loop: max. 50 m	
Technology type	Zigbee	
Operating frequency:	2.405 GHz to 2.48 GHz	
Max. radio-frequency power transmitted:	2.5 mW	
Compatible plate ranges	Iconic, Iconic Styl, Iconic Essence, Pro Series	
Mounting centres	84 mm pattern plate	
Compliance	Safety:	AS/NZS 60669.2.1
	EMC:	AS/NZS 60669.2.1
	RF:	AS/NZS 4268
Power failure data retention	Internal date/time retained for at least 6 hours. Settings preserved indefinitely.	
Environmental rating	IP20 (designed for indoor use only)	
Operating humidity	5 % – 90 % relative humidity, non-condensing	

Specifications typical at 25 °C

#### Derating

For multi-gang applications, derate the maximum load rating of each module as shown in the table below. The load figures are based on a nominal voltage of 220-240 V AC.

Primary modules per plate	Max. load per primary module
1	300 W
2	225 W
3	150 W

#### Trademarks

- Zigbee® is a registered trademark of the Connectivity Standards Alliance.
- Wiser™ is a trademark and the property of Schneider Electric SE, its subsidiaries and affiliated companies.

Other brands and registered trademarks are the property of their respective owners.

#### Customer Care

##### Warranty information

We warrant this product for 2 years. See Warranty links below.

##### Schneider Electric (Australia) Pty Ltd

33-37 Port Wakefield Road, Gepps Cross SA 5094

Customer Care: 13 73 28

Email: [customercare.au@se.com](mailto:customercare.au@se.com)

Warranty: <https://www.clipsal.com/warranty>

[www.clipsal.com](http://www.clipsal.com)

##### Schneider Electric (NZ) Ltd

Level 2, Building 6, 60 Highbrook Drive

Highbrook, Auckland 2013

Customer Care: 0800 652 999

Email: [sales@nz.schneider-electric.com](mailto:sales@nz.schneider-electric.com)

Warranty: <https://www.se.com/nz/en/about-us/legal/terms-and-conditions.jsp>

[www.pdl.co.nz](http://www.pdl.co.nz)