

# User Manual

## Data Logger

Logger1000A/Logger1000B



---

# All Rights Reserved

## All Rights Reserved

No part of this document can be reproduced in any form or by any means without the prior written permission of Sungrow Power Supply Co., Ltd (hereinafter "SUNGROW").

## Trademark

**SUNGROW** and other Sungrow trademarks used in this manual are owned by SUNGROW. All other trademarks or registered trademarks mentioned in this manual are owned by their respective owners.

## Software Licenses

- It is prohibited to use data contained in firmware or software developed by SUNGROW, in part or in full, for commercial purposes by any means.
- It is prohibited to perform reverse engineering, cracking, or any other operations that compromise the original program design of the software developed by SUNGROW.

# About This Manual

The manual mainly contains the product information, as well as guidelines for installation, operation and maintenance. Readers can get additional information at [www.sungrowpower.com](http://www.sungrowpower.com) or on the webpage of the respective component manufacturer.

## Validity

This manual is valid for the following models:

- Logger1000A (4G version)
- Logger1000B (non-4G version)

It is referred to as "Logger1000" hereinafter unless otherwise specified.

## Target Group

This manual is intended for qualified technicians who are responsible for installation, operation, and maintenance of the product, and users who need to check inverter parameters.

The product must only be installed by qualified technicians. The qualified technical technician must:

- Have electronic, electrical wiring, and mechanical expertise, and be familiar with electrical and mechanical schematics.
- Have received professional training related to the installation and commissioning of electrical equipment.
- Be able to respond quickly and effectively to dangers or emergencies that may occur during installation and commissioning.
- Be familiar with local standards and relevant safety regulations of electrical systems.
- Read this manual thoroughly and understand the safety instructions related to operations.

## How to Use This Manual

Read through this manual carefully before using the product, and keep it properly in an easy-to-reach place.

The information in this manual is subject to ongoing updates and revisions. Although efforts have been made to ensure accuracy, there might be slight variations or errors compared to the actual product. Please refer to the actual product purchased, and the latest manual can be obtained from [support.sungrowpower.com](http://support.sungrowpower.com) or sales channels.

## Security Declaration

For details on the product's network security vulnerability response process and vulnerability disclosure, please visit the following website:

<https://en.sungrowpower.com/security-vulnerability-management>

## Symbols

This manual contains important safety instructions, which are highlighted with the following symbols, to ensure personal and property safety during usage, or to help optimize the product performance in an efficient way.

Symbols used in this manual are listed below. Please review carefully for better use of this manual.

### **DANGER**

Indicates high-risk potential hazards that, if not avoided, will result in death or serious injury.

### **WARNING**

Indicates moderate-risk potential hazards that, if not avoided, may lead to death or serious injury.

### **CAUTION**

Indicates a slightly hazardous situation which, if not avoided, may result in minor or moderate injury.

### **NOTICE**

Indicates potential risks that, if not avoided, may lead to device malfunction or financial losses.



"NOTE" indicates additional information, important content, or helpful tips that may solve problems or save time.

# Contents

---

All Rights Reserved.....	I
About This Manual.....	II
<b>1 Safety Instructions.....</b>	<b>1</b>
1.1 Understanding Safety Signs.....	1
1.2 General Safety Instructions.....	1
1.3 Packaging, Transportation, and Storage Safety.....	3
1.4 Installation Safety.....	4
1.5 Electrical Connection Safety.....	5
1.6 Operation and Maintenance Safety.....	5
1.7 Disposal Safety.....	6
<b>2 Product Overview.....</b>	<b>8</b>
2.1 Product Description.....	8
2.2 Function Overview.....	10
2.3 Indicators.....	10
2.4 System Structure.....	11
2.4.1 Photovoltaic (PV) System.....	11
2.4.2 Energy Storage System.....	13
<b>3 Unpacking and Storage.....</b>	<b>15</b>
3.1 Scope of Delivery.....	15
3.2 Unpacking and Inspection.....	16
3.3 Storage Requirements.....	16
<b>4 Mechanical Installation.....</b>	<b>18</b>
4.1 Safety Notes.....	18
4.2 Mounting Requirements.....	18
4.3 Installation Tools.....	20
4.4 Mounting the Data Logger.....	21
4.4.1 Mounting on the Wall.....	21
4.4.2 Mounting on the DIN Rail.....	23

4.5	Installing the Antenna.....	25
4.6	Installing the Power Box.....	26
<b>5</b>	<b>Electrical Connection.....</b>	<b>27</b>
5.1	Safety Notes.....	27
5.2	Ports Overview.....	28
5.3	Preparing Cables.....	29
5.4	Establishing Inverter Connections.....	29
5.4.1	RS485 Terminal Block Connection.....	29
5.4.2	RJ45 Port Connection.....	31
5.4.3	Connecting to Multiple Inverters.....	33
5.5	Connecting Multiple Data Loggers.....	34
5.6	Connecting to the Energy Meter.....	34
5.6.1	RS485 Port Connection.....	35
5.6.2	Ethernet Connection.....	36
5.7	Connecting to the Meteo Station.....	37
5.7.1	RS485 Port Connection.....	38
5.7.2	AI Port Connection.....	38
5.8	Connecting to the Power Box.....	39
5.9	Connecting to the Backend Monitoring System.....	41
5.10	Installing the Micro-SIM Card.....	42
5.11	Connecting to the Emergency Stop Device.....	42
<b>6</b>	<b>Inspection before Commissioning.....</b>	<b>43</b>
<b>7</b>	<b>Commissioning.....</b>	<b>44</b>
7.1	Establishing a Connection.....	44
7.1.1	Establishing a Connection via Wireless Hotspot.....	44
7.1.2	Establishing a Connection via Ethernet.....	44
7.2	Logging to the Web UI.....	45
7.2.1	Local Login.....	45
7.2.2	Remote Login via Maintenance Link.....	46
7.3	Overview.....	46
7.3.1	Web UI Overview.....	47
7.3.2	Compatibility.....	48
7.4	Modifying Password.....	49
7.5	Initial Configuration Using the Setup Wizard.....	49

7.6 Selecting Usage Scenario of Web UI.....	51
<b>8 Configuring Data and Network Interfaces.....</b>	<b>53</b>
8.1 RS485 Communication Ports.....	53
8.2 Ethernet.....	53
8.3 Mobile Network.....	54
8.4 WLAN.....	55
8.5 Analog Input (AI) Port.....	55
8.6 Digital Inputs (DI) Port.....	56
8.7 Digital Output (DO) Port.....	57
<b>9 Configuring Data Communication and Transfer Protocols.....</b>	<b>59</b>
9.1 Setting iSolarCloud Parameters.....	59
9.2 Setting IEC104 Parameters.....	60
9.2.1 IEC104 Forwarding Table.....	60
9.2.2 Setting IEC104 Parameters using Forwarding Table.....	61
9.2.3 Setting Communication Interruption Protection.....	62
9.2.4 Restricting IEC104 Communication to Authorized Devices.....	63
9.2.5 Adding a Peer Device.....	63
9.2.6 Configuring SSL Encryption.....	64
9.3 Setting Modbus Parameters.....	64
9.3.1 Setting Communication Interruption Protection.....	65
9.3.2 Restricting Modbus Communication to Authorized Devices.....	65
9.3.3 Adding a Peer Device.....	66
9.3.4 Configuring Serial Port Parameters.....	66
9.3.5 Configuring SSL Encryption.....	66
9.4 Setting Parameters for Third-Party Portal.....	67
9.5 Setting Echonet Parameters.....	68
<b>10 Device Administration.....</b>	<b>69</b>
10.1 Adding SUNGROW Inverters.....	69
10.2 Adding a Third-Party Device.....	69
10.2.1 Selecting Device.....	69
10.2.2 Importing Device Information by Setting Measuring Points.....	70
10.2.2.1 Verifying Measuring Point Data.....	70
10.2.2.2 Saving Configuration as Template.....	70
10.2.3 Importing Device Information Using a Configuration File.....	71

10.3	Configuring Device Parameters.....	71
10.3.1	Configuring Parameters for Inverters.....	71
10.3.2	Configuring Parameters for Meter.....	72
10.3.3	Configuring Parameters for Batteries.....	73
10.3.4	Setting Meteo Sensor Parameters.....	73
10.3.5	Correcting Cumulative Power Generation.....	74
10.4	Automatic Frequency Point Assignment.....	74
10.5	Uploading Physical Layout.....	75
10.6	Controlling SUNGROW Inverter.....	76
10.7	Editing Device Information.....	76
10.8	Updating Devices.....	77
10.9	Removing Devices.....	78
10.10	Enabling Arc Fault Circuit Interrupter (AFCI) Function.....	78
<b>11</b>	<b>Device Monitoring.....</b>	<b>79</b>
11.1	Viewing Power Plant and Device Operation Information.....	79
11.2	Viewing Alarms.....	80
<b>12</b>	<b>Exporting Data.....</b>	<b>81</b>
12.1	Exporting Logs of Connected Devices.....	81
12.2	Exporting Logs of Logger1000.....	81
12.3	Exporting Communication Packets.....	82
12.4	Exporting Fault Recorder Data.....	82
<b>13</b>	<b>Power Control (PV System).....</b>	<b>83</b>
13.1	Function Description.....	83
13.2	Interface Description.....	84
13.2.1	Digital Control Interface.....	84
13.2.2	Analog Control Interface.....	86
13.2.3	DRM Control Interface.....	86
13.3	Options for Power Control Method.....	87
13.4	Selecting Power Control Mode.....	87
13.5	Settings for Active Power Control.....	88
13.5.1	Remotely Regulating Active Power.....	88
13.5.1.1	Open-Loop Control.....	89
13.5.1.2	Closed-Loop Control.....	89
13.5.2	Locally Regulating Active Power.....	90



13.5.2.1	Open-Loop Control.....	90
13.5.2.2	Closed-Loop Control.....	91
13.5.2.3	Configuring Adjustment Time and Target Values.....	93
13.5.3	Regulating Active Power via Analog Input.....	94
13.5.4	Regulating Active Power via Digital Input.....	96
13.5.5	Regulating Power via DRM.....	97
13.5.6	Regulating Active Power via Country Mode.....	97
13.5.6.1	Korea.....	97
13.5.6.2	Japan.....	97
13.5.7	Disabling Active Power Control.....	99
13.5.8	Prohibiting the Inverter from Reducing Power Output.....	99
13.6	Settings for Reactive Power Control.....	99
13.6.1	Remotely Regulating Reactive Power.....	99
13.6.2	Locally Regulating Reactive Power.....	100
13.6.3	Regulating Reactive Power via Analog Input.....	101
13.6.4	Regulating Reactive Power via Digital Input.....	102
13.6.5	Regulating Reactive Power via Country Mode.....	103
13.6.6	Disabling Reactive Power Control.....	104
13.6.7	Disabling Reactive Power Output.....	104
13.7	Setting Emergency Stop.....	104
13.8	Configuring Cascaded Scheduling.....	105
<b>14</b>	<b>Power Control (Energy Storage System).....</b>	<b>106</b>
14.1	Settings for Active Power Control.....	106
14.1.1	Power Regulation using Digital Inputs.....	106
14.1.1.1	Controlling Power via DRM.....	106
14.1.1.2	Controlling Power via Ripple Control.....	106
14.1.1.3	Setting Emergency Stop.....	107
14.1.2	Local Power Control.....	108
14.1.3	Remote Power Control.....	111
14.2	Settings for Reactive Power Control.....	111
14.3	Configuring Cascaded Scheduling.....	112
<b>15</b>	<b>Energy Management.....</b>	<b>113</b>
15.1	Requirements.....	113
15.1.1	Adding a Meter.....	113

15.1.2 Controlling Grid-Connection Power.....	114
15.2 Selecting Energy Management Working Modes.....	116
15.2.1 Self-Consumption.....	117
15.2.1.1 Demand Control.....	118
15.2.1.2 Adding Battery Usage Plan.....	121
15.2.2 Time Plan.....	124
15.2.2.1 Selecting the Time Plan Mode.....	125
15.2.2.2 Configuring Battery Usage Plan.....	125
15.2.3 Virtual Power Plant (VPP) Dispatching.....	126
15.2.4 Compulsory Mode.....	126
15.3 Configuring Cascaded Scheduling.....	127
<b>16 Maintaining the Data Logger.....</b>	<b>128</b>
16.1 Setting System Time.....	128
16.2 Enabling Remote Maintenance.....	128
16.3 Updating the Logger1000.....	129
16.4 Restarting Logger1000.....	130
16.5 Restoring to the Factory Settings.....	130
16.6 Viewing the Firmware Version.....	130
16.7 Viewing History Operations.....	131
16.8 Certificate Management.....	131
<b>17 User Management.....</b>	<b>133</b>
17.1 User Roles and Permissions.....	133
17.2 Factory Default Passwords.....	134
17.3 Setting Up Administrator Account.....	134
17.4 Creating O&M Users.....	134
17.5 Deleting O&M Users.....	135
17.6 Resetting Account Password.....	135
17.6.1 Resetting O&M Account Password.....	135
17.6.2 Resetting Administrator Account Password.....	136
17.7 Setting Account Security Parameters.....	136
17.8 Enabling the O&M Mode.....	137
<b>18 Troubleshooting.....</b>	<b>138</b>
<b>19 Routine Maintenance.....</b>	<b>140</b>
19.1 Safety Notes.....	140

19.2 Maintenance Items.....	140
19.3 Module-Level Rapid Shutdown.....	141
19.4 Replacing Logger1000.....	142
<b>20 Appendix.....</b>	<b>144</b>
20.1 Technical Data.....	144
20.2 Cable Routing Requirements.....	145
20.3 Quality Assurance.....	145
20.4 Contact Information.....	146

# 1 Safety Instructions

When installing, commissioning, operating, and maintaining the product, strictly observe relevant safety instructions. Improper use or misoperation may result in:

- Injury or death to the operator or a third party.
- Damage to the product or the property of the operator or a third party.

Strictly follow the safety instructions stated in the manual to avoid the hazards mentioned above.



- The safety instructions in this manual are only supplements and cannot cover all the precautions that should be followed. Perform operations considering actual on-site conditions.
- SUNGROW shall not be held liable for any damage caused by violation of general safety operation requirements, general safety standards, or any safety instruction in this manual.
- When installing, operating, and maintaining the device, comply with local laws and regulations. The safety precautions in this manual are only supplements to local laws and regulations.

## 1.1 Understanding Safety Signs

Symbol	Description
	Read the instructions before performing any operations on the product.
	Do not dispose of the equipment as household waste.

## 1.2 General Safety Instructions

### Regulatory Requirements

- All operations related to the product must comply with relevant laws and regulations of the country or region.
- Obtain permission from the local power department before grid-connected operation.
- Ensure all safety labels on the product remain clear and visible throughout the entire product life cycle. Do not remove, paint over, block or damage any labels or nameplates on the product.

- Ensure that the materials used comply with relevant environmental protection and health and safety standards.
- Take appropriate fire safety measures in accordance with applicable fire safety requirements, such as using flame-retardant materials and installing fire alarm systems.

## Personnel Requirements

### **DANGER**

**Operators are strictly prohibited from wearing watches, rings, necklaces or other conductive items, which may cause electric shock burns.**

### **WARNING**

**If any condition or malfunction that may endanger personal safety or damage equipment is found during operations related to the product, stop operations immediately and do not continue using the product.**

- Only trained and authorized personnel may operate and maintain the product.
- Operators must understand the correct use of tools and be familiar with all safety precautions mentioned in this manual.
- All operations related to the product must be performed by qualified personnel wearing personal protective equipment.
- All equipment and tools used during product operation and maintenance must be inspected regularly.

## Environmental Requirements

### **DANGER**

**Do not use or place the product in flammable, explosive or corrosive gas environments.**

### **WARNING**

**Do not operate the product in severe weather such as thunderstorms, rain, snow, Level 6 or stronger winds, including but not limited to transportation, installation, electrical connection, power-on, maintenance and high-altitude operations.**

### **WARNING**

**In case of fire, evacuate the building or product area and call the fire department. Do not re-enter the burning area.**

**NOTICE****Dust and moisture may damage the product!**

- **Take appropriate measures such as keeping the product clean and dry if installation or electrical connection needs to be interrupted.**
- Ensure there are no heat sources or flames near the product to prevent overheating or malfunctions.
- Ensure there are no obstructions around the product, maintaining enough ventilation and heat dissipation space.
- Ensure there are no liquids around the product and it is far from areas where liquids may be present to avoid risks of short circuits and electrical faults.
- Avoid using equipment in environments with smoke, dust or other particulate matter.
- Ensure that the product does not interfere with other devices or is affected by interference when operating in an electromagnetic field environment.
- Ensure the working environment temperature and humidity for the product are within specified ranges.

### 1.3 Packaging, Transportation, and Storage Safety

**⚠ CAUTION****Improper handling may cause personal injury!**

- **When manually handling the product, the operator must wear personal protective equipment.**
- **When handling the product, consider its weight and keep the balance to prevent it from tilting or falling.**

**NOTICE****Improper transportation may cause personal injury or product damage!**

- **Select suitable transportation tools based on the product dimensions and weight.**
- **Products should be placed horizontally during transportation, with suitable packaging materials to fix the product in place or prevent impact.**
- **Avoid collisions or severe vibrations during transportation.**

**NOTICE**

Improper storage may cause product damage!

- Do not store the product without packaging.
- Do not store the product outdoors or in direct sunlight.

**NOTICE**

Products stored for over six months should undergo strict protection and necessary inspections. If necessary, install the product only after it has been tested by qualified personnel.

## 1.4 Installation Safety

** DANGER**

Improper installation may cause fire hazards!

- Make sure the product has no electrical connections before installation.
- Prevent foreign objects from entering the interior of the product during installation.

** WARNING**

Modification of the product without authorization is strictly prohibited. Unauthorized modifications may lead to serious safety risks, damage product performance, and even cause personal injury.

** CAUTION**

When wall drilling is required during installation, ensure that there are no electric cables and water pipes in the wall.

**NOTICE**

Keep the installation area clean.

- Clean up materials and tools used after product installation.
- Clean empty packaging materials such as cardboard boxes, foam, plastic and zip ties in the operation area.

## 1.5 Electrical Connection Safety

### DANGER

Improper wiring may cause personal injury!

- Comply with the regulations and standards related to the local grid during wiring.
- Electrical connection must be performed by qualified personnel wearing personal protective equipment.
- Before making electrical connections, use a measuring device to ensure the cable is not live. Otherwise, there could be a risk of electric shock!
- Check the power cord and confirm that the identifier is correct before connecting it.
- Use insulated tools during wiring work to prevent short circuits.

## 1.6 Operation and Maintenance Safety

### DANGER

High voltage exists during product operation, and improper operation may endanger personal safety or damage the product!

- Do not touch the enclosure, as there may be risks of electric shock.
- Do not touch energized components, as there may be risks of electric shock.
- Do not touch hot components, as there may be risks of burns.
- Do not dismantle any parts of the product, as there may be risks of electric shock.

### DANGER

Damaged product or system failures may cause electric shock or fire!

- Visually inspect the product for damage or other hazards before troubleshooting.
- Ensure all connections are secure.



** DANGER**

**Improper maintenance may cause personal injury or product damage!**

- Before maintenance, switch off all power connections to the product, including internal power supply.
- Ensure the product will not be powered on accidentally.
- Maintenance must be performed by qualified personnel wearing protective equipment and ensuring there are no voltage or current.
- Place prominent warning signs or safety tape around the area to prevent unauthorized access or accidents.
- If there are parts in the operation area that may carry voltage, cover them with insulated cloth for insulation shielding.

** WARNING**

**Improper maintenance may cause personal injury or product damage!**

- Check the warning labels on the enclosure and follow label requirements.
- Confirm that the product, associated external devices, or circuit connections are safe.
- For products that have been powered off for an extended period, a comprehensive inspection must be carried out before powering on, and they can only be put back into use after being checked and tested by qualified personnel.

## 1.7 Disposal Safety

** CAUTION**

**Disposed products may contain hazardous substances or potential hazards!**

- When disposing of products, comply with local, national, and international regulations and standards.
- During the transportation, storage, and disposal of discarded products, ensure proper measures are taken to prevent the leakage and contamination of hazardous substances, protecting soil, water sources, and air quality.
- Ensure that operators have the necessary training and personal protective equipment, and follow safety procedures. If necessary, entrust a professional team to handle the disposal of products.

**NOTICE**

**Before disposing of products, ensure proper measures are taken to protect data security during the disposal process. This includes using methods such as data erasure, destruction, or encryption to prevent sensitive information from being leaked or misused.**

**NOTICE**

**Before disposing of products, ensure safety markings, warning labels, and nameplates are clearly visible.**

## 2 Product Overview

### 2.1 Product Description

The Logger1000 is a device designed for data collection, power control, and protocol conversion in PV power plants. It combines communication gateway and power plant maintenance functions, providing flexible networking, convenient maintenance, and user-friendly operation.



Unless otherwise noted, illustrations are based on the Logger1000A.

### Product Appearance

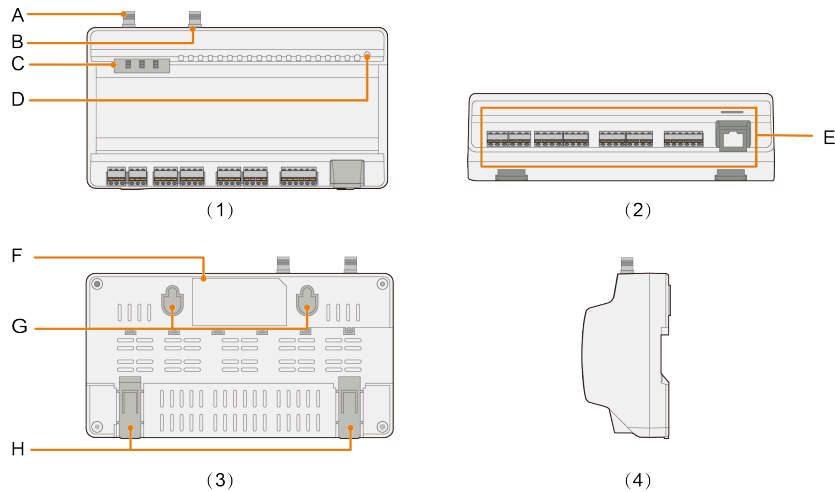

**figure 2-1** Appearance. (1) Front view; (2) Bottom view; (3) Rear view; (4) Side view

The images provided in this document are for reference only, and the actual ones may differ.

Item	Name	Description
A	WLAN antenna mounting hole	-
B	4G antenna mounting hole	Only the Logger1000A is equipped with a 4G antenna mounting hole.
C	Indicators	Indicates the running state of the Logger1000
D	Reset button	Press and hold it for > 3s to restart. Press and hold it for > 60s to restore the default settings.

Item	Name	Description
E	Wiring area	See <a href="#">5.2 Ports Overview</a> .
F	Nameplate	-
G	Wall-mounting holes	Used for wall-mounting
H	Mounting clips	Used for DIN-rail mounting

### Nameplate

**WARNING**

The nameplate contains important parameters, which must be kept visible and free of stains and damage.



Position	Description
A	Brand and product name
B	Product model
C	Serial number
D	Technical data
E	Safety and certification marks
F	Company name, website and place of manufacture

### Dimensions

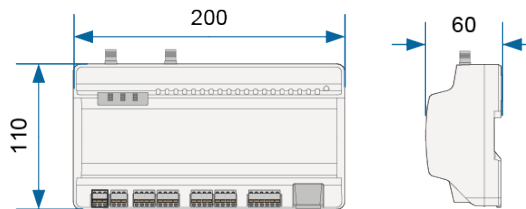

figure 2-2 Dimensions (unit: mm)

## 2.2 Function Overview

- **Device Monitoring:** Logger1000's Web UI allows operation and maintenance (O&M) personnel to monitor device status in real-time. They can track the operating conditions of connected devices, identify and address faults promptly.
- **Remote configuration and maintenance:** O&M personnel can access the Web UI remotely to perform routine maintenance task. These include as updating system configuration, modifying device parameters, which helps in reducing maintenance costs.
- **Power control:** The power output of inverters can be controlled through the Web UI. This feature allows O&M personnel to adjust relevant parameters in response to changes in power demand, enhancing the operational reliability of the power station.
- **Energy Management:** With SUNGROW hybrid inverters and batteries connected, O&M personnel can fine-tune the energy usage strategies via the Web UI. This optimization ensures efficient energy utilization and a stable, continuous power supply.

## 2.3 Indicators

Indicator (print)	LED color	LED status	Description
RUN	Red/green	Off	No external power supply connected
		Flashing green (every 1 second)	Normal operation
		Flashing red	Faults found in connected inverters
		Steady red	The Logger1000 cannot operating normally
4G*	Blue	Off	No data communication
		Steady on	Connection via 4G is established
		Blinking	Communication connection is being established
WLAN	Blue	Off	No data communication
		Steady on	Connection via WLAN is established

Indicator (print)	LED color	LED status	Description
		Blinking	Communication connection is being established

Note: \* Only the Logger1000A is equipped with the 4G indicator.



When the 4G or WLAN indicator on the Logger1000 is slowly flashing, it indicates the Logger1000 is establishing a connection to the iSolarCloud. If there is no data communication between the Logger1000 and iSolarCloud for 10 seconds, the indicator will remain steady.

## 2.4 System Structure

### Maximum Number of Connected Devices

The Logger1000 supports connecting a maximum of 30 devices. Devices refer to all components connected via ports and exchanging data with the Logger1000, such as inverters, meteo station, meteo sensor and energy meter in PV power generation systems.

#### 2.4.1 Photovoltaic (PV) System

The Logger1000 is used for real-time monitoring of the operational status and performance indicators of a PV power generation system. It collects and records data from inverters and other devices, facilitating operations and maintenance management as well as power adjustments.

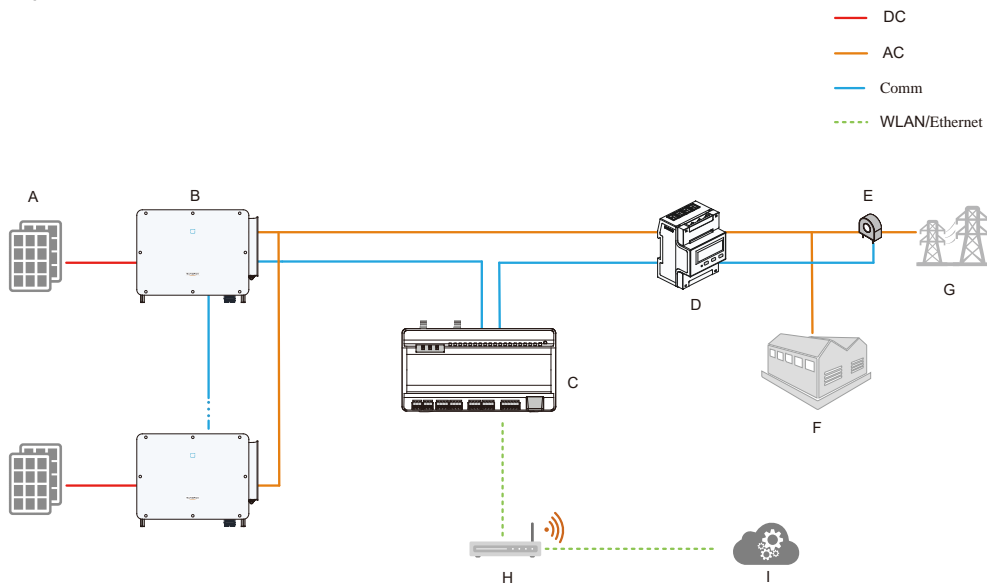

Position	Name	Description
A	PV panel	Converts sunlight into electricity.
B	Photovoltaic (PV) inverter	Converts direct current (DC) generated by PV panels into alternating current (AC).
C	Data Logger	Device model: Logger1000 Handles and collects data from various devices in a power station, supporting operation and maintenance (O&M) and power control.
D	Smart energy meter	Measures the usage of electrical energy.
E	Current transformer	Measures the current intensity in AC cables.
F	Loads	Any device that consumes electrical energy, such as home appliances or industrial machinery.
G	Grid	-
H	Router	Provides network connectivity, allowing devices within the system to communicate with each other and exchange data with external systems or cloud platforms.
I	iSolarCloud	Used for remote monitoring, management, and analysis of the operation of power stations.

### 2.4.2 Energy Storage System

For energy storage systems that have integrated batteries and storage inverters, the Logger1000 not only monitors the operational data and performance metrics of the system but also enables comprehensive management of electrical energy.

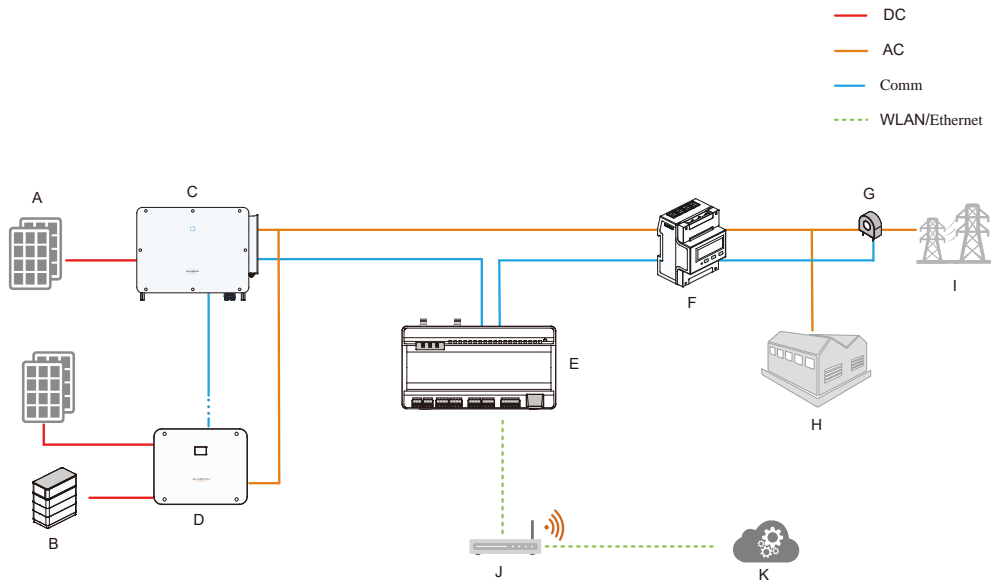

Position	Name	Description
A	PV panel	Converts sunlight into electricity.
B	Battery	Stores electrical energy for supply to loads.
C	Photovoltaic (PV) inverter	Converts direct current (DC) generated by PV panels into alternating current (AC).
D	Hybrid inverter	Converts direct current (DC) electricity into alternating current (AC) and controls how electrical energy is stored and released to facilitate energy use.
E	Data Logger	Device model: Logger1000 Handles and collects data from various devices in a power station, supporting operation and maintenance (O&M) and power control.
F	Smart energy meter	Measures the usage of electrical energy.
G	Current transformer	Measures the current intensity in AC cables.
H	Loads	Any device that consumes electrical energy, such as home appliances or industrial machinery.



<b>Position</b>	<b>Name</b>	<b>Description</b>
I	Grid	-
J	Router	Provides network connectivity, allowing devices within the system to communicate with each other and exchange data with external systems or cloud platforms.
K	iSolarCloud	Used for remote monitoring, management, and analysis of the operation of power stations.

## 3 Unpacking and Storage

### 3.1 Scope of Delivery

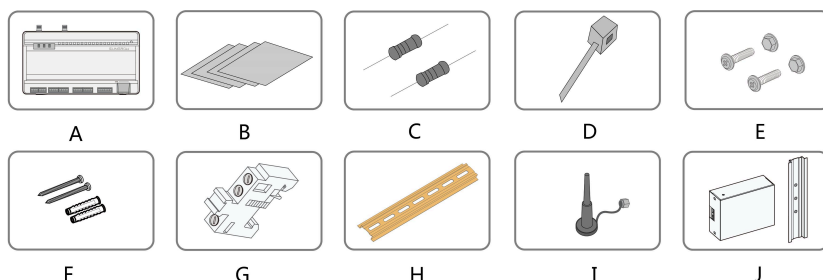

figure 3-1 Scope of delivery

Item	Name	Description
A	Data Logger	Logger1000
B	Documents	Quick Installation Guide, quality certificate, packing list, product test report, and warranty card
C	Communication terminal resistor	6x120Ω Note: When there are more than 15 devices on the RS485 bus, it is recommended to directly parallel a 120Ω terminal resistor at the RS485 A and RS485 B ports of the first and last devices on the bus.
D	Nylon cable tie	Used to tie cables
E	Fastener assembly	4 sets, M4x16, used for wall-mounting to secure the Logger1000 on the metal surface
F	Expansion bolt	4 sets, ST4.8x19, used for wall-mounting to secure the Logger1000 on the concrete wall
G	DIN rail end brackets	2 sets, E/UK-1201442, used to secure the Logger1000 on the DIN rail
H	DIN rail (top-hat rail)	Length: 240mm
I	WLAN antenna/4G antenna	Only the Logger1000A is equipped with the 4G antenna mounting hole. Refer to the actual product received.
J	Power box	Converts the AC current into DC current. Length of the provided DIN rail: 170mm

## 3.2 Unpacking and Inspection

The product is thoroughly inspected and packed before delivery. However, it is possible for damage to occur during transport. Check the following items carefully once receiving the product.

- Check if the packing list matches the items included in the delivery.
- Check the product thoroughly and ensure there are no visible damages.
- Confirm that the received model is the same as the purchased one.
- Verify that all safety signs, warning labels, and the nameplate on the product are clear and legible.



If any damage is found, do not proceed with the installation, and contact the forwarding company or SUNGROW. Please provide photos of the damaged areas to facilitate the service process.

## 3.3 Storage Requirements

If the product is not immediately installed or operated on-site after completing delivery acceptance, store it properly.



If the product will not be installed immediately, store it in its original packaging.

### NOTICE

**Losses caused by storage not in accordance with this manual are not covered by the warranty.**

- If stacking packaged products, stack no more than 8 layers vertically and take additional protective measures.
- Store the product in a ventilated, dry, and clean indoor environment with its packaging.
- Ensure that the storage carrier can support the weight of the packaged product.
- Ensure the device is kept in a well-ventilated and moisture-proof place, without accumulation of water.
- Ambient temperature:  $-40^{\circ}\text{C}\sim+70^{\circ}\text{C}$ . Relative humidity: 0~95%, no condensation.
- Consider the surrounding harsh environment like sudden temperature changes or collision to avoid product damage.

- Carry out inspections periodically. Check whether the packaging is intact and prevent any damage that may be caused by pests and animals. Replace the packaging immediately if it is damaged.
- Conduct regular inspection, preferably at least once a week. Check the packaging for signs of damages and prevent insects and or rodents. Replace the packaging immediately if it is damaged.

## 4 Mechanical Installation

### 4.1 Safety Notes

#### WARNING

**Improper installation may cause personal injury or product damage!**

- Further operations can only be performed after professional evaluation by SUNGROW that the installation environment meets requirements.
- Only intact and undamaged products can be installed.
- Tighten the product or related equipment to the specified torque to avoid affecting product performance and lifespan.

#### NOTICE

**Losses resulting from installation not in accordance with this manual are not covered by the warranty.**

### 4.2 Mounting Requirements

Select the best installation location for the Logger1000 is important for ensuring its safe operation, prolonging its lifespan, and maintaining performance.

#### Environment Requirements

#### NOTICE

**High humidity in the installation environment may cause internal component damage to the Logger1000.**

#### NOTICE

**When connecting outdoor equipment, such as a Meteo Station, to the Logger1000, install a Surge Protection Device (SPD) to protect the communication system. Select the proper SPD based on the site conditions and requirements.**

- The mounting location must be indoors.
- No inclination installation is allowed.
- Temperature and humidity must meet the following requirements.

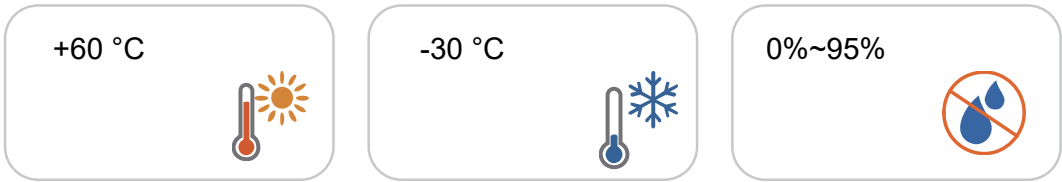

- Protect the product from moisture and chemically corrosive substances.
- When installed horizontally, ensure the installation position allows for easy visibility of indicators.

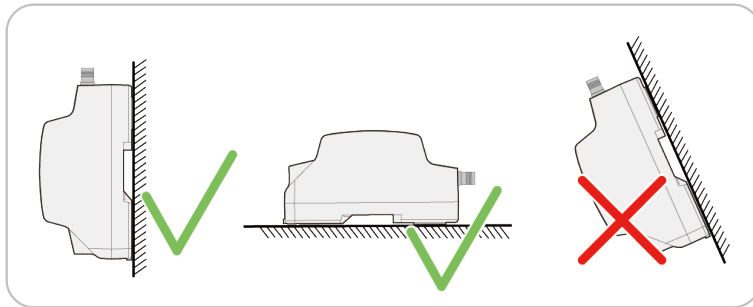

**Clearance Requirements**

Ensure that the installation space for the product meets the requirements for of heat dissipation, maintenance, while reserving an appropriate distance based on the surrounding conditions.

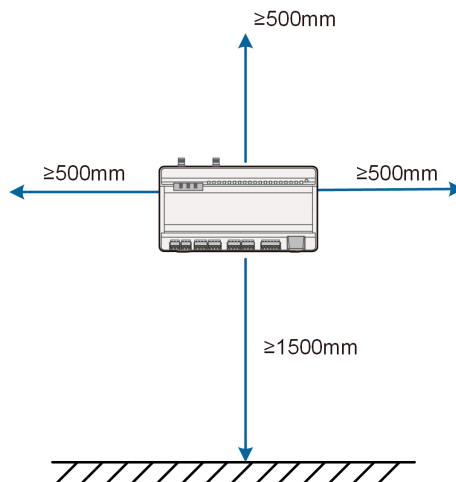

**figure 4-1** Minimum spacing

**i** When determining the installation location, ensure the power cable from the power box can reach and connect to the power input port of the Logger1000.

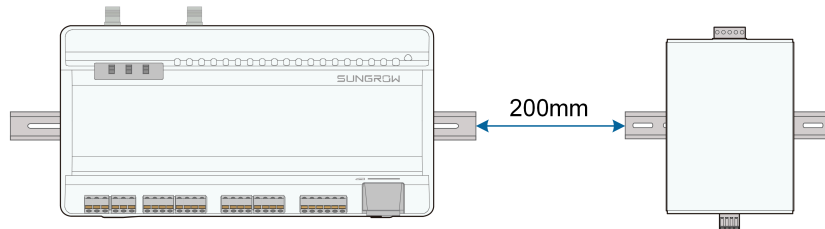
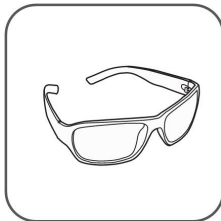

**figure 4-2** Spacing with the power box

### 4.3 Installation Tools

**i** Installation tools are not included in the supply scope and must be prepared by the installer.

Installation tools include, but are not limited to, the following recommended ones. If necessary, use other auxiliary tools on site.



Protective eyewear

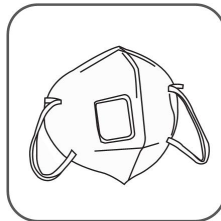

Dust mask

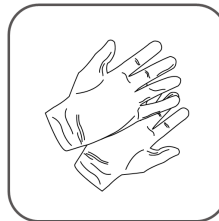

Insulated gloves

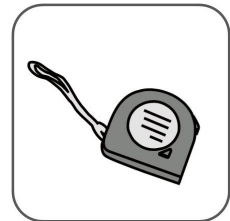

Measuring tape



Marker

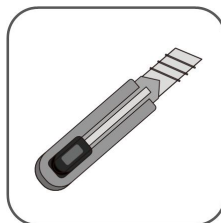

Utility knife



Electric screwdriver



Phillips screwdriver

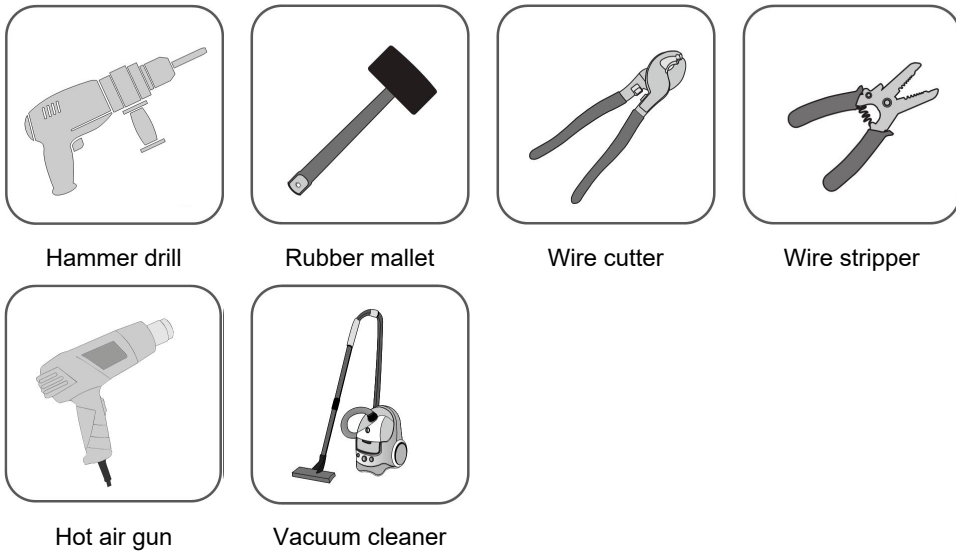

## 4.4 Mounting the Data Logger

The Logger1000 can be mounted on the wall, or on the DIN rail.

### 4.4.1 Mounting on the Wall

Secure the Logger1000 through the wall-mounting holes.

#### Prerequisites

#### **⚠ WARNING**

**Make sure to avoid water pipes and electricity wiring in the wall before drilling.**

- The wall surface is smooth and secure.
- Operation personnel have worn protective eyewear and dust mask to prevent dust from entering eyes or being inhaled.

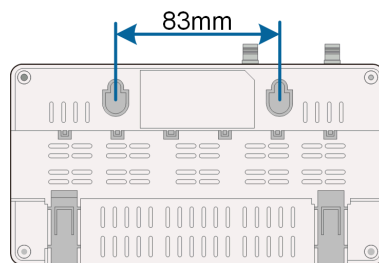

**figure 4-3** Wall-mounting hole dimensions



**step 1** Mark positions for drilling holes with a marker.

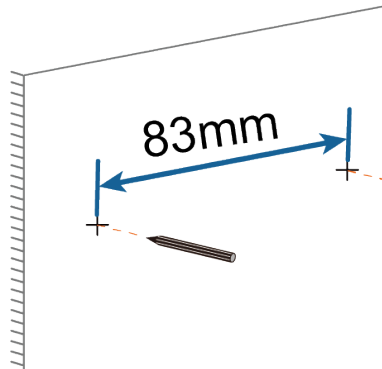

**step 2** Drill the holes with a drill at the marked positions.

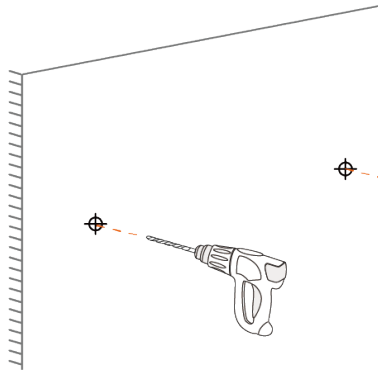

**step 3** For installation on a concrete wall, insert expansion bolts into the drilled holes, and tighten them so that approximately 5mm of the bolt protrudes from the wall surface.

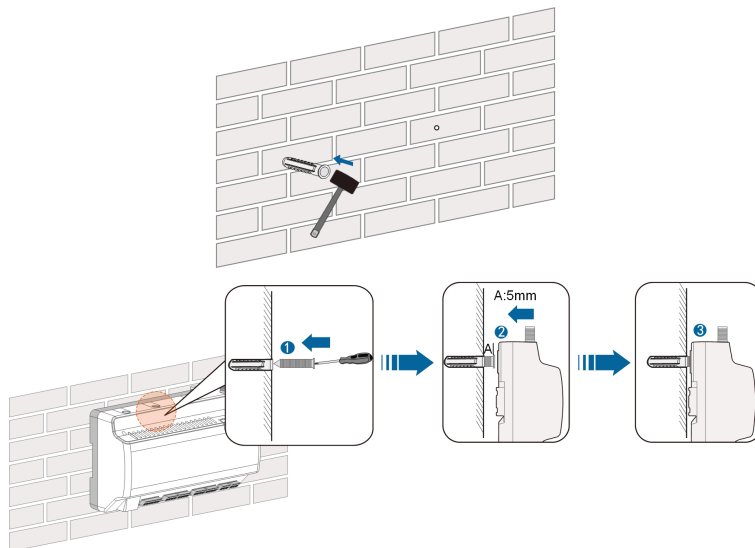

**step 4** For installation on a metal wall, secure the Logger1000 using bolts and nuts, ensuring that the bolts extend approximately 5mm beyond the wall surface.

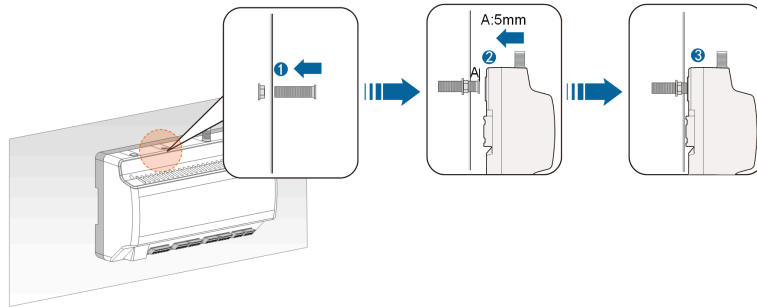

**step 5** Align the mounting holes of the Logger1000 with the protruding bolts.

**step 6** Double-check the Logger1000 to make sure it is firmly installed.

- - End

#### 4.4.2 Mounting on the DIN Rail

Secure the Logger1000 in place on the DIN rail using the mounting clips.

##### Prerequisites

- The DIN rail is installed at the desired location, and is securely fastened.

**step 1** Use a flat-head screwdriver or a similar tool to gently press down on the recessed part of the Logger1000's mounting clips, then pull the clips outward to prepare for attachment.

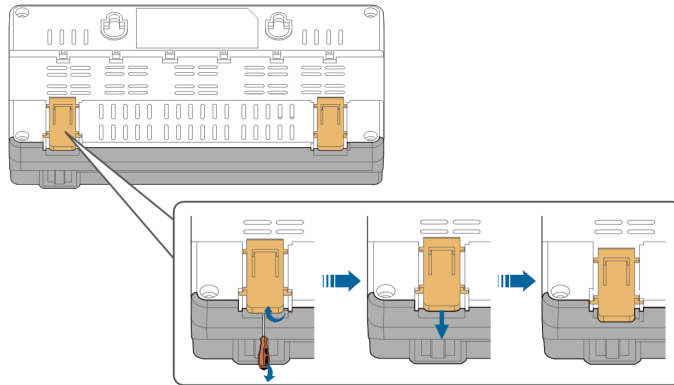

**step 2** Hold the Logger1000 parallel to the DIN rail and align the central mounting hook with the rail.

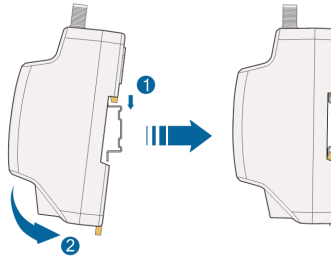

**step 3** Push the mounting clips upwards to its original position to lock the Logger1000 onto the DIN rail.

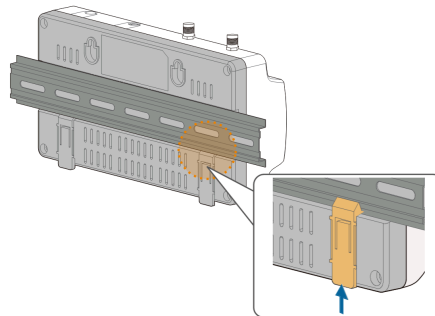

**step 4** Tighten the end brackets at both ends of the DIN rail to prevent any lateral movement of the Logger1000.

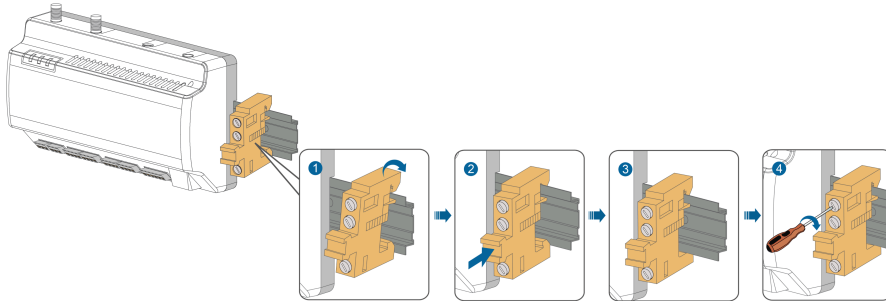

**step 5** Double-check the Logger1000 to make sure it is firmly installed.

-- End

## 4.5 Installing the Antenna

### Prerequisites

#### NOTICE

**For optimal signal reception, ensure the antenna with its suction cup base is positioned outside of any metal enclosures or metal walls. Metal surfaces can significantly interfere with signal strength.**

- The suction cup base has already been fixed outside the metal enclosure or metal wall.
- An antenna outlet has been reserved (diameter: 20mm).

**step 1** Lead the threaded end of antenna cable towards the Logger1000.

**step 2** Align the threaded end of the antenna cable with the designated 4G or WLAN antenna mounting hole on the Logger1000, and hand-tighten the attached nut in a clockwise direction until it is secure.

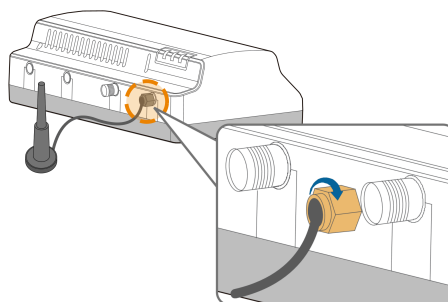

-- End

## 4.6 Installing the Power Box

Secure the power box in place on the DIN rail using the mounting clips.

### Prerequisites

- The DIN rail is installed at the desired location, and is securely fastened.
- The power box is positioned at an appropriate distance from the Logger1000, and the power cable can be connected to the power input port of the Logger1000.

**figure 4-4** Mounting hook of the power box

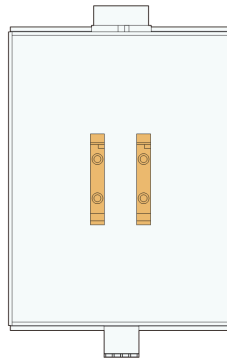

**step 1** Hold the power box parallel to the DIN rail and align the central mounting hook with the rail.

**step 2** Press down the power box until it snaps into place with an audible "Click" sound.

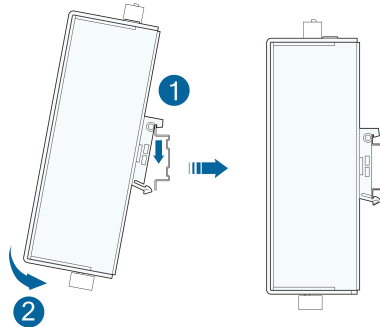

**step 3** Double-check the power box to make sure it is firmly installed.

-- End

# 5 Electrical Connection

## 5.1 Safety Notes

### WARNING

Improper wiring may cause personal injury or product damage!

- Only complete and undamaged products can be proceeded with electrical connection.
- Fasten terminals with the specified torque to prevent electrical faults.

### NOTICE

Improper wiring may cause product damage!

- Cables used must meet specifications, have secure connections and is well-insulated.
- Do not pull cables or wires forcefully during electrical connections to avoid damaging their insulation.
- Ensure sufficient bending space for all cables and wires.
- Take necessary auxiliary measures to reduce the stress on cables or wires.
- Keep cables at a sufficient distance from heat-generating components to prevent insulation deterioration or damage due to high temperatures.

### NOTICE



Losses caused by electrical connection not in accordance with this manual are not covered by the warranty.

## 5.2 Ports Overview

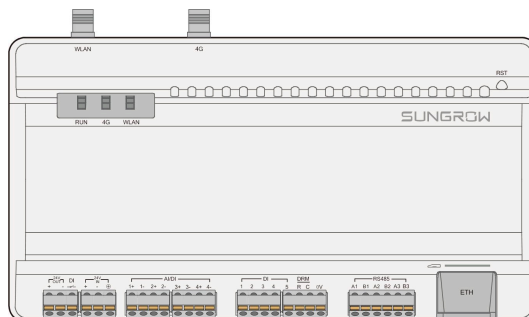
External wiring area are located at the bottom of Logger1000.



**table 5-1** Port description

Port	Function	
24V OUT	24V power output	24V±5%, the max. output current: 0.5A
DI	Converts AI into DI	Enabling switch for converting AI function to DI function
24V IN	24V power input	24V±3%
	Grounding	Connecting protective grounding cable
AI/DI	Compatible with AI/DI function	Default AI input sampling: 0-10V or 4-20mA
DI	Digital input	Digital signal input
DRM	DRM (Demand Response Modes) function	Works together with DI1 to DI4 ports to implement the Demand Response Management (DRM) function.
0V	Digital reference point	-
RS485	RS485 communication port	Support of 3 inputs of RS485
 *	SIM card slot	Support of Micro-SIM card
ETH	Ethernet port	Connect to the backend monitoring system through devices such as switches and routers.
WLAN	WLAN antenna	-
4G*	4G antenna	-

Port	Function	
RST	Reset	Press and hold it for > 30s to restore the default settings. Press and hold it for < 3 seconds, reserved

Note: \* Only the Logger1000A is equipped with the SIM card slot and the 4G function.



The RS485 (A1B1~A3B3) port only supports a communication distance of up to 1000m.

### 5.3 Preparing Cables

Cable	Specification	Remarks
RS485 cable	Two-core or multi-core cables with a cross-sectional area of 1.5mm <sup>2</sup> or a gauge of 20 AWG.	Shielded twisted pair
RJ45 Ethernet cable	CAT5E	Shielded twisted pair
Signal cables for AI, DI, and DO	Two-core or multi-core cables with a cross-sectional area of 1.5mm <sup>2</sup> or a gauge of 20 AWG.	-
Power cable	A two-core cable with a cross-sectional area of 1.5mm <sup>2</sup> or a gauge of 20 AWG.	-
DC cable, AC cable	Cables with a cross sectional area of 1mm <sup>2</sup> ~1.5mm <sup>2</sup>	-
Grounding Cable	Cables with a cross sectional area of 1mm <sup>2</sup> ~1.5mm <sup>2</sup>	-

### 5.4 Establishing Inverter Connections

Establish a connection between the Logger1000 and the inverter.

For SUNGROW inverters, establish a connection with the Logger1000 using either the inverter's RS485 terminal block or RJ45 port, depending on the actual setup and requirements.

#### 5.4.1 RS485 Terminal Block Connection

##### Prerequisites

- An RS485 communication cable that meets the specifications is available. See [5.3 Preparing Cables](#).



**⚠ DANGER**

**Accidental contact with live terminals may cause fatal electric shock!**

- Ensure the product is powered off before wiring.
- Ensure terminals are not live before wiring.

**NOTICE**

**The RS485 communication cable must be a shielded twisted pair with single-point grounding of the shielding.**

**step 1** Lead the RS485 cable from the inverter to the wiring area of the Logger1000.

**step 2** Strip 15 mm of the sheath from the product end of the RS485 cable, and strip 8~10 mm of the insulation using a wire stripper.

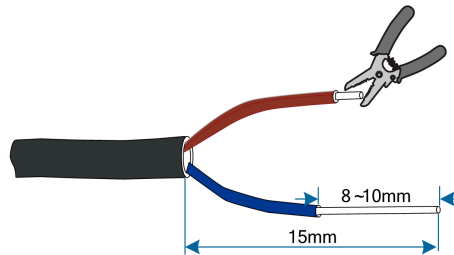

**step 3** Crimp and connect the stripped wires to the proper terminal block, and plug the terminal block to the RS485 port of the Logger1000.

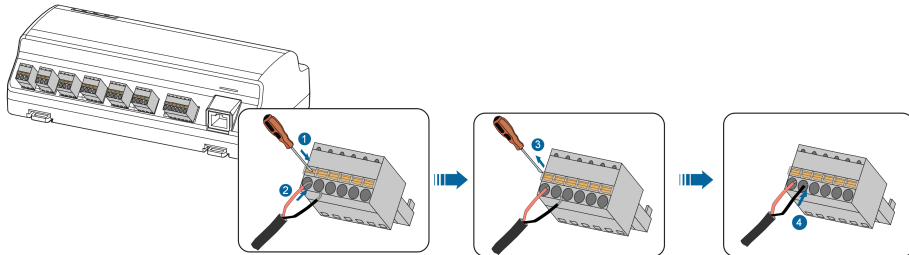

**NOTICE**

Connect RS485A to port A and RS485B to port B.

**step 4** Connect the other end of the RS485 cable to the RS485 port of the inverter.

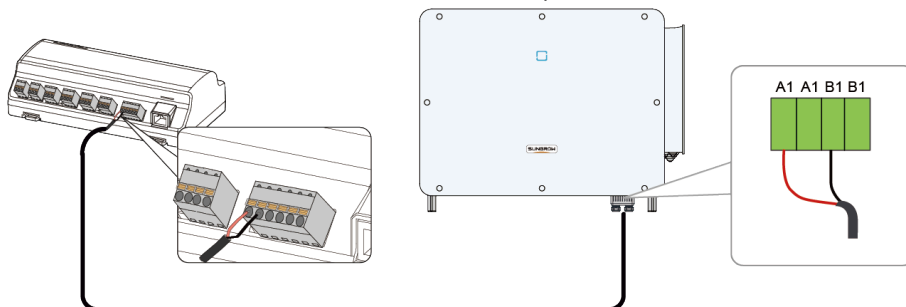

-- End

## 5.4.2 RJ45 Port Connection

### Prerequisites

- An RJ45 communication cable that meets the specifications is available. See [5.3 Preparing Cables](#).

### **⚠ DANGER**

**Accidental contact with live terminals may cause fatal electric shock!**

- **Ensure the product is powered off before wiring.**
- **Ensure terminals are not live before wiring.**

**step 1** Lead the RJ45 communication cable from the inverter to the wiring area of the Logger1000.

**step 2** Prepare the communication cable.

- Strip the insulation of the RJ45 cable with an Ethernet wire stripper. Gently separate and pull out the wires connected to pin 3 (green/white) and pin 6 (green).

The wires from pin 3 and pin 4 are used for communication connection.

The wire from pin 3 should be connected to the terminal designated for RS485- B, and the wire from pin 6 to the terminal designated for RS485+ A.

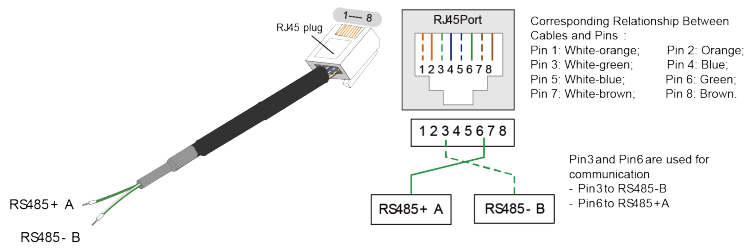

- ii. Put bootlace ferrule onto the wires and crimp them using a crimping tool.
- iii. Trim unused wires and slide a piece of heat-shrink tubing over the end of the RJ45 cable.
- iv. Heat the tubing using a heat gun, until it fits tightly around the cable.

**step 3** Connect the stripped wires to the terminal block, and plug the terminal block to the RS485 port of the Logger1000.

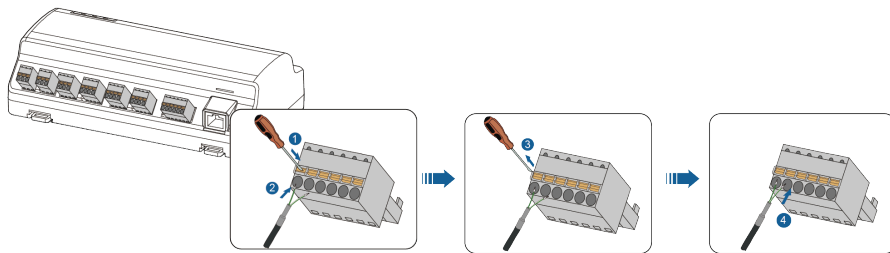

**step 4** Insert the RJ45 plug into the inverter and ensure it snaps into place.

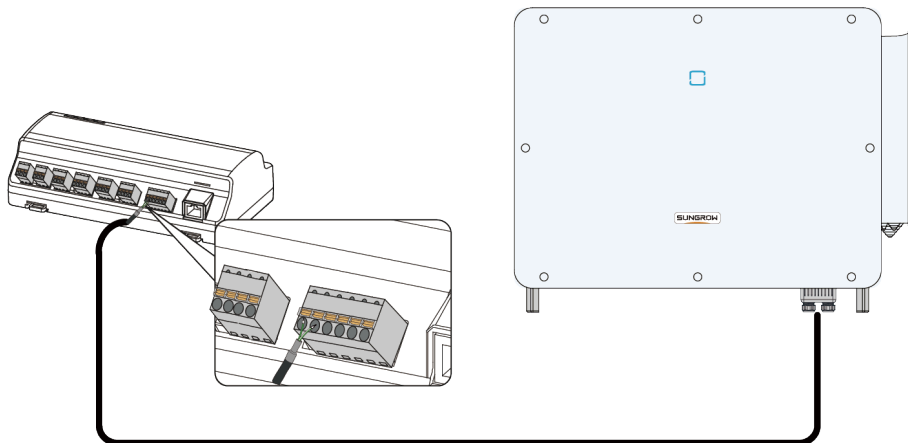

-- End

### 5.4.3 Connecting to Multiple Inverters

Establish connections between the Logger1000 and multiple inverters to enable comprehensive monitoring and management of connected devices. When communicating with multiple inverters, the inverters are connected to each other in a daisy chain manner using RS485 communication cables.

#### **⚠ DANGER**

**Accidental contact with live terminals may cause fatal electric shock!**

- **Ensure the product is powered off before wiring.**
- **Ensure terminals are not live before wiring.**

#### **NOTICE**

**When connecting outdoor devices, it is recommended to add lightning protection devices, otherwise the Logger1000 may be damaged by a lightning strike.**

#### **Wiring Instructions**

- When there are more than 15 devices on the RS485 bus (more than 14 devices excluding the data logger), it is recommended to directly parallel a 120Ω terminal resistor at the RS485 A and RS485 B ports of the first and last devices on the bus.
- When the number of device types is less than or equal to the number of RS485 ports of the Logger1000, it is recommended to connect different types of devices to different RS485 ports.
- On each RS485 bus, the baud rate, data bits, stop bits, and parity bits of all devices must be consistent with the RS485 communication parameters of the Logger1000's COM port.
- The address of each device on the RS485 bus must be within the address range set by the Logger1000, and there must be no duplicates, otherwise communication will fail.
  - Address range for SUNGROW inverters: 1~247
  - Address range for third-party inverters: 1~255

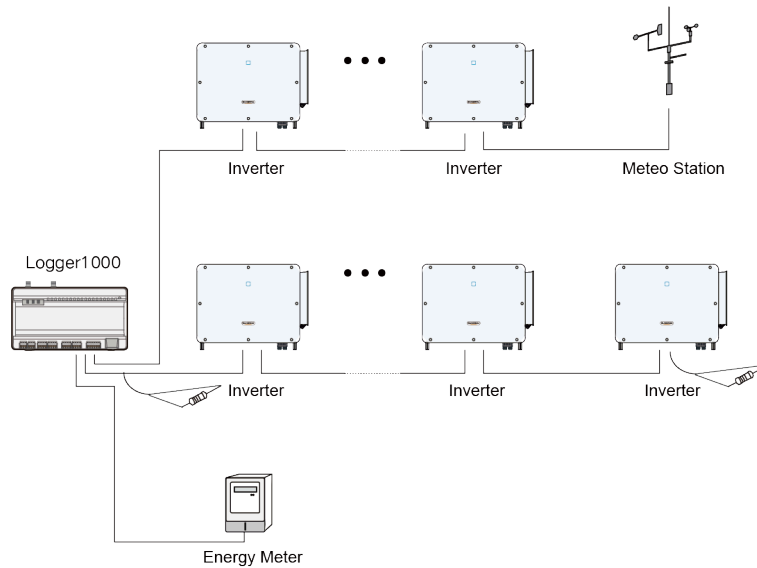

figure 5-1 Logger1000 connecting to multiple inverters

## 5.5 Connecting Multiple Data Loggers

Connecting multiple Logger1000 devices to a core switch or 4G router enables data transmission to the backend or the iSolarCloud, thereby facilitating centralized data management and monitoring.

### **⚠ DANGER**

**Accidental contact with live terminals may cause fatal electric shock!**

- **Ensure the product is powered off before wiring.**
- **Ensure terminals are not live before wiring.**

**step 1** Connect multiple Logger1000 devices to the same core switch or router.

**step 2** Perform basic configuration for each Logger1000.

-- End

## 5.6 Connecting to the Energy Meter

Connect the Logger1000 to an energy meter to read meter data in real time for recording and analysis.

Logger1000 can be connected to the Smart Energy Meter through RS485 port or Ethernet port.



It is recommended to use a meter that complies with the DL/T645-1997/2007 protocol or Modbus protocol requirements.

**table 5-2** Recommended models of energy meter

Manufacturer	Model	Protocol Type	Wiring
Sfere	PD194E/Z		
Acrel	PZ96-E3		
	DTSD1352		
Weidmueller	EM 610	Modbus RTU	<a href="#">5.6.1 RS485 Port Connection</a>
SUNGROW	DTSU666		
	DTSU666-20		
Schneider	IEM3255		
Janitza	UMG604/UMG 104	• Modbus RTU	• <a href="#">5.6.1 RS485 Port Connection</a>
		• Modbus TCP	• <a href="#">5.6.2 Ethernet Connection</a>

### 5.6.1 RS485 Port Connection

#### Prerequisites

- All devices on each RS485 bus need to be configured with the same serial port parameters.

#### **⚠ DANGER**

**Accidental contact with live terminals may cause fatal electric shock!**

- **Ensure the product is powered off before wiring.**
- **Ensure terminals are not live before wiring.**



When using Weidmüller or Janitza meters, connect the RS485 A/B port of the meter to the RS485 B/A port of the Logger1000.

Connect the RS485 cable led from the Smart Energy Meter to the RS485 port of the Logger1000.

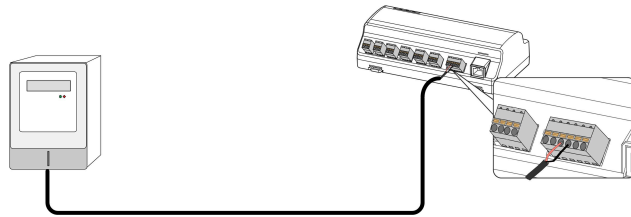

## 5.6.2 Ethernet Connection

### Prerequisites

- Two appropriately sized network cables have been prepared.
- An Ethernet switch is available.

### **⚠ DANGER**

**Accidental contact with live terminals may cause fatal electric shock!**

- **Ensure the product is powered off before wiring.**
- **Ensure terminals are not live before wiring.**



For optimal transmission effects, it is recommended to use shielded cables of CAT5E or higher. Ensure that the actual usage distance does not exceed 90 meters.

**step 1** Insert the RJ45 plug of the Ethernet cable led from the Smart Energy Meter to the Ethernet switch.

**step 2** Connect one end of the other Ethernet cable to the Ethernet switch, and the other end to the "ETH" port of the Logger1000.

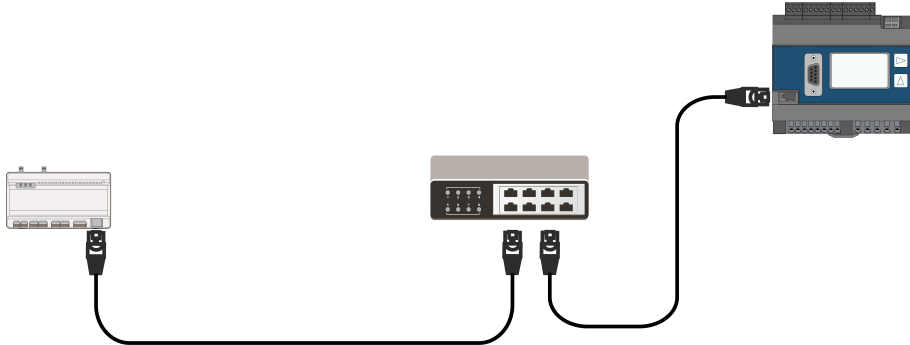

**step 3** Optional: If a switch is not used, directly connect the cable from the meter to the "ETH" port of the Logger1000.

-- End

## 5.7 Connecting to the Meteo Station

Connect the Logger1000 to environmental monitoring equipment to obtain and monitor environmental data such as temperature and humidity.

Meteo Station can be connected to Logger1000 through RS485 port or AI port.



It is recommended to use Meteo Station that complies with the Modbus protocol.

**table 5-3** Recommended models of Meteo Station

Model	Wiring
PC-4	
PC-4 PRO	
WING-TRACKER	
WS601	
SMP10	<a href="#">5.7.1 RS485 Port Connection</a>
RT1	
PVMet75	
PVMet200	
Si-RS485TC	
TEMPER_SENSOR	<a href="#">5.7.2 AI Port Connection</a>



Model	Wiring
Meteo sensor	

### 5.7.1 RS485 Port Connection

#### **⚠ DANGER**

**Accidental contact with live terminals may cause fatal electric shock!**

- Ensure the product is powered off before wiring.
- Ensure terminals are not live before wiring.

Connect RS485 cable led from the Meteo Station to the RS485 port of the Logger1000.



If multiple inverters and Meteo Station are connected to the Logger1000 at the same time, the Meteo Station should be connected to the end of the daisy chain.

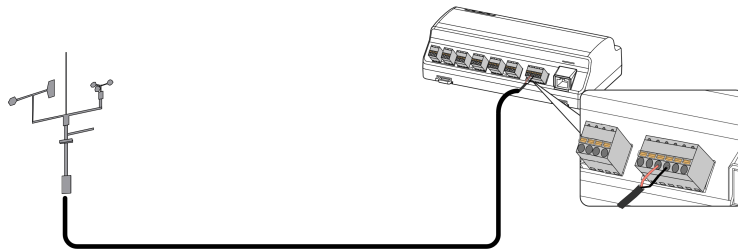

### 5.7.2 AI Port Connection

#### **⚠ DANGER**

**Accidental contact with live terminals may cause fatal electric shock!**

- Ensure the product is powered off before wiring.
- Ensure terminals are not live before wiring.

Connect the communication cable led from the meteo sensor to the AI port of the Logger1000.

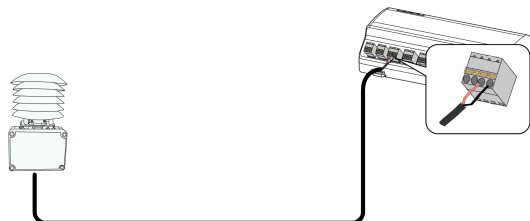

## 5.8 Connecting to the Power Box

### Prerequisites

- Two-core DC cable, three-core AC cable, and grounding cable that meet the specifications have been prepared. See [5.3 Preparing Cables](#).

### **⚠ DANGER**

**Accidental contact with live terminals may cause fatal electric shock!**

- **Ensure the product is powered off before wiring.**
- **Ensure terminals are not live before wiring.**

**step 1** Strip 15 mm of the sheath from both the DC and AC cables, and strip 8~10 mm of the insulation using a wire stripper.

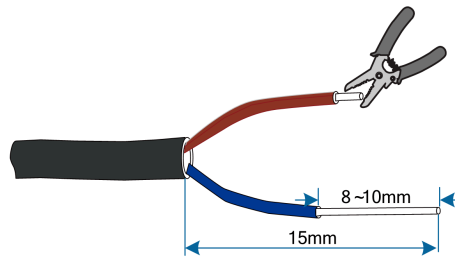

figure 5-2 DC cable

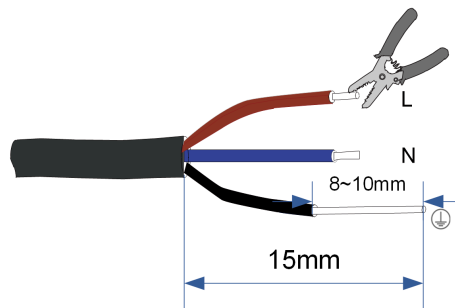
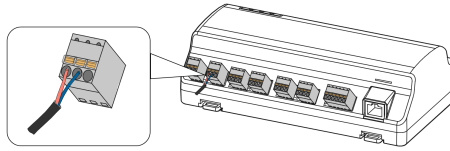

figure 5-3 AC cable

**step 2** Strip 8~10 mm of the sheath from the grounding cable using a wire stripper.



**step 3** Connect the stripped DC cable wires to the terminal block, and plug the terminal block into the "24V IN" port of the Logger1000.



If other devices require 24V DC power, use a DC cable to connect the "24V OUT" port of the Logger1000 to the "24V IN" port of that device, following the steps mentioned above.

**step 4** Connect the stripped grounding cable to the corresponding port of the Logger1000.

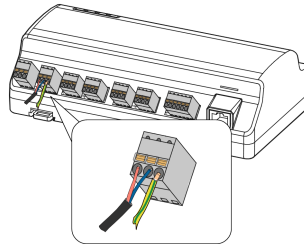

**step 5** Connect the DC cable led from the "24V IN" port of the Logger1000 to the "DC 24V OUT" port of the power box.

**step 6** Connect the stripped AC cable wires to the "AC (100~277V)" port of the power box, and connect the other end of the AC cable to the 220V AC power.

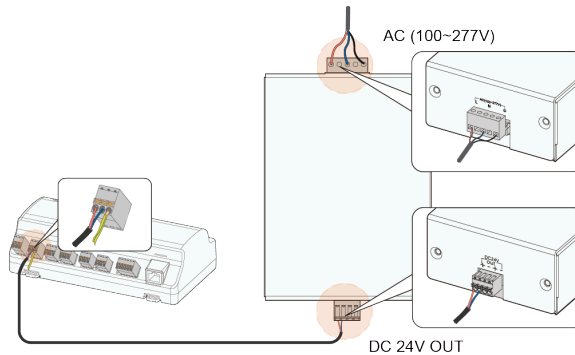

#### NOTICE

Ensure that the power source meets the requirements for Limited Power Source (LPS) or Power Source 2 (PS2).

-- End

## 5.9 Connecting to the Backend Monitoring System

Connect the Logger1000 to multiple monitoring system platforms to achieve data transmission and remote monitoring.

Using Modbus TCP or IEC104 communication protocols, the Logger1000 can be connected to the backend monitoring system. As a slave device, the Logger1000 allows multiple backends to access, supporting up to 15 Modbus TCP and 15 IEC104 links.

### Prerequisites

- Two appropriately sized network cables have been prepared.
- An Ethernet switch is available.



To connect the Logger1000 to multiple monitoring control centers, an Ethernet switch or router can be used.

Using an Ethernet switch as an example:

**step 1** Insert one end of the network cable into the Ethernet switch port, and the other end into the "ETH" port of the Logger1000.

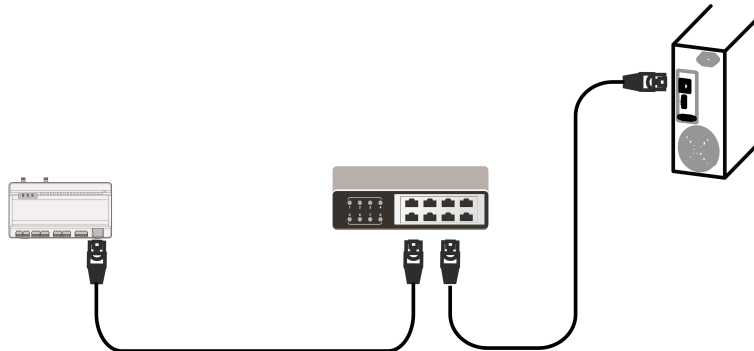

Default IP address of the "ETH" port: 12.12.12.12.

**step 2** Configure the IP address of the Logger1000's "ETH" port so that it is in the same subnet as the backend monitoring system.

-- End

## 5.10 Installing the Micro-SIM Card

To enable wireless communication functions for the Logger1000, install the Micro-SIM card.

### Prerequisites

- Micro-SIM card size: 12mm x 15mm.



Only the Logger1000A supports installing a Micro-SIM card.

Insert the Micro SIM card into the SIM card slot.

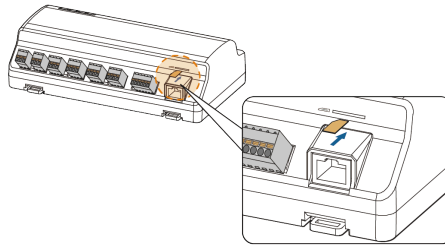

The Micro-SIM card supports hot-plugging.

## 5.11 Connecting to the Emergency Stop Device

Digital signals from the emergency stop device can be transmitted to the Logger1000.



The DI5 port should only be used for connecting the emergency stop device. The emergency stop device is not included in the scope of delivery.

Connect the signal wire from the emergency stop device to the "DI5" port, and the ground wire to the "0V" port of the Data Logger.

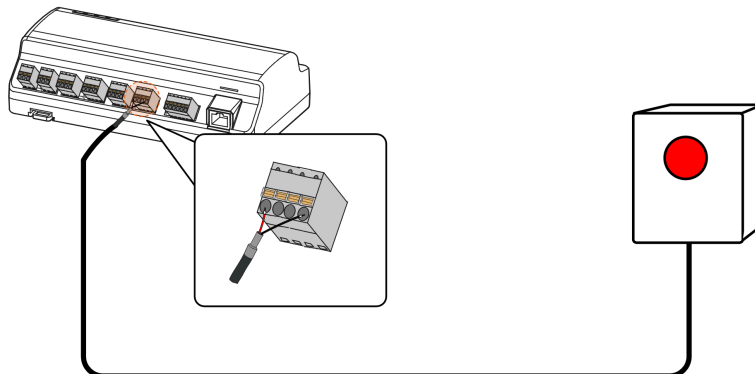

## 6 Inspection before Commissioning

No.	Check Item	Result
1	All cables are intact, well-insulated, and appropriately dimensioned.	<input type="checkbox"/>
2	All cables are connected correctly and firmly.	<input type="checkbox"/>
3	The polarity of the power supply cable is correct. The grounding cable is reliably grounded.	<input type="checkbox"/>

# 7 Commissioning



The content presented in this manual, including screenshots, parameters, value ranges, and default values, is intended solely for reference purposes. Always refer to the actual interface for up-to-date and precise information.

## 7.1 Establishing a Connection

### 7.1.1 Establishing a Connection via Wireless Hotspot

#### Necessary information for connection

- SSID: SG-[device S/N number] (for example, **SG-A1234567890**)
- IP address of the Logger1000: **11.11.11.1**

**step 1** On your PC, navigate to the wireless network settings, and connect to Logger1000's network.



The serial number (S/N) can be found on the Logger1000's front label.

**step 2** Open your web browser and enter **11.11.11.1** in the address bar to navigate to Logger1000's Web UI.



For LOGGER-SV300.001.00.P044 or later, to log in to the Logger1000 Web system, enter the IP address manually: <https://11.11.11.1>

-- End

### 7.1.2 Establishing a Connection via Ethernet

#### Prerequisites

- The Logger1000 is connected to the PC using an Ethernet cable.

#### Necessary information for login

- Default IP address of the ETH port: **12.12.12.12**
- Default subnet mask: **255.255.255.0**

**step 1** Set your PC's network card to match the Logger1000's network segment.  
For example, assign an IP address to your PC within the same range: **12.12.12.125**, with the subnet mask set to **255.255.255.0**.



The IP address should have the same first three octets as the Logger1000. The fourth octet should be unique within the range of 1 to 254 to avoid conflicts (excluding 12, which is used by the Logger1000).

**step 2** Open your web browser and enter **12.12.12.12** in the address bar to navigate to Logger1000's Web UI.



For LOGGER-SV300.001.00.P044 or later, to log in to the Logger1000 Web system, enter the IP address manually: `https://12.12.12.12`

-- End

## 7.2 Logging to the Web UI

**table 7-1** Factory Default Passwords

Username	User role	Initial password
maintain	O&M user	pw1111
administrator	System administrator	pw@111111



Starting from firmware version P035, the Logger1000 Web UI supports user management. See [17 User Management](#) .

### 7.2.1 Local Login

For example, log in as a O&M user:

**step 1** Enter your login credentials based on the page displayed.

If...	Then...
The Web UI navigates to the login page	<ol style="list-style-type: none"> <li>Enter the username: <b>maintain</b>.</li> <li>Enter the default password <b>pw1111</b>.</li> <li>Click <b>Login</b>.</li> </ol>
The Web UI displays the page <b>General Information</b> .	<ol style="list-style-type: none"> <li>In the upper right of the page, click <b>Login</b> to open the dialog box.</li> <li>Enter the default password <b>pw1111</b>.</li> <li>Click <b>Login</b>.</li> </ol>



After logging in, the Web UI defaults to the interface with O&M user permissions.

**step 2** Check the firmware version, and verify if the Logger1000 needs updating. See [16.6 Viewing the Firmware Version](#).



If an update is needed, see [16.3 Updating the Logger1000](#) .

-- End

## 7.2.2 Remote Login via Maintenance Link

### Prerequisites

- Remote maintenance is enabled on this Logger1000.
- The necessary maintenance information is provided.

For example, log in as a O&M user:

**step 1** Enter the address <https://rm.isolarcloud.com> in the browser address bar and navigate to the remote maintenance portal.

**step 2** Select the server site and product category.

- Server site: Select as instructed in the remote maintenance information provided.
- Product category: Select communication device.

**step 3** Enter the device S/N and password.

**step 4** Log in and navigate to the Logger1000's login page.

**step 5** Enter the username: **maintain**.

**step 6** Enter the initial password **pw1111**, and click **Login**.

After logging in, the Web UI defaults to the interface with O&M user permissions.







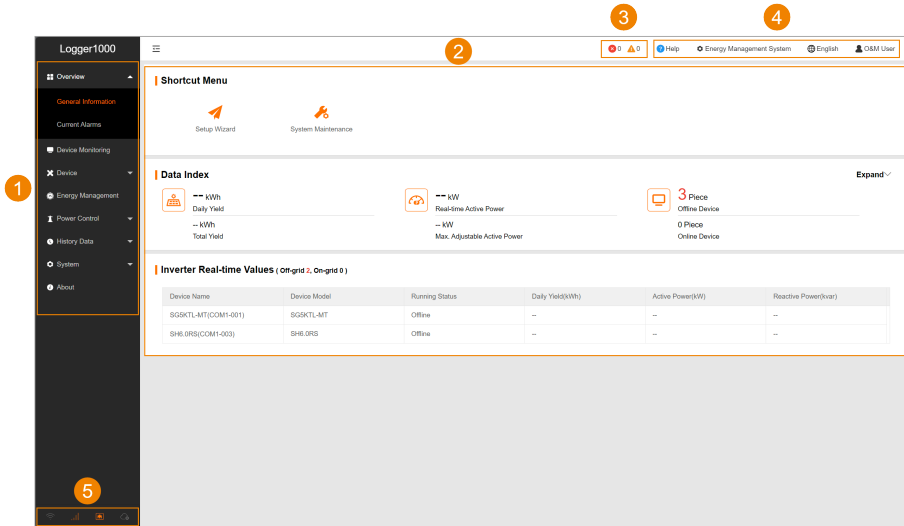

-- End

## 7.3 Overview

### 7.3.1 Web UI Overview



Position	Name	Description
1	Navigation bar	<ul style="list-style-type: none"> <li>• <b>Overview:</b> View general device information and real-time fault status.</li> <li>• <b>Device Monitoring:</b> Monitor the current operational status of devices in real time.</li> <li>• <b>Device:</b> Manage settings and configurations for connected devices.</li> <li>• <b>Energy Management:</b> Configure the usage strategy for the energy storage system.</li> <li>• <b>Power Control:</b> Control the power output of SUNGROW inverters.</li> <li>• <b>History Data:</b> View history operations.</li> <li>• <b>System:</b> View the system information.</li> <li>• <b>About:</b> View the firmware information.</li> </ul>
2	Function area	Display the current page.

Position	Name	Description
3	Alarm bar	<p>Display the number of fault and alarms for the currently connected devices.</p> <ul style="list-style-type: none"> <li> /  : View the number of faults and alarms for inverters.</li> <li> /  : View the number of faults and alarms for RSDs. Displayed only when RSDs are connected.</li> </ul>
4	Toolbar	View help information, switch usage scenarios, change interface language, or update personal information.
5	Status bar	<p>Displays the communication status:</p> <ul style="list-style-type: none"> <li> WLAN</li> <li> Mobile network</li> <li> Ethernet</li> <li> iSolarCloud</li> </ul>



The Web UI features different usage scenarios, which result in variations in the navigation bars and available functions.



Unless otherwise noted, the following descriptions are based on the permissions of an O&M user.



Upon first logging into the Web UI, the page **Help** appears by default.

### 7.3.2 Compatibility

Type	Description
Browser	<ul style="list-style-type: none"> <li>IE11 or above</li> <li>Chrome65 or above</li> <li>Safari11 or above</li> </ul>
Min. resolution	1024×768

## 7.4 Modifying Password

It is recommended to change the password after initial login.



Not changing the default password can lead to unauthorized access, and continued use of the initial password increases the risk of theft and hacking. Additionally, loss of the password can prevent access to the device, potentially causing losses to the power station. In these cases, SUNGROW shall not be liable for any losses incurred due to non-compliance with the recommended security practices.



If you forgot password, contact the relevant administrator.

**step 1** Click **O&M User > Modify Password** to open the corresponding dialog.

**step 2** Enter the old password and the new password.

**step 3** Click **Save**.

-- End

## 7.5 Initial Configuration Using the Setup Wizard

Upon your initial login, use the wizard to complete network configuration, grid commissioning, and power station setup.

### Prerequisites

- The Logger1000 is able to connect to the Internet.
- The user has O&M user permissions.



During the initial setup process, you can navigate through different configuration items by clicking **Previous** or **Next** as needed.

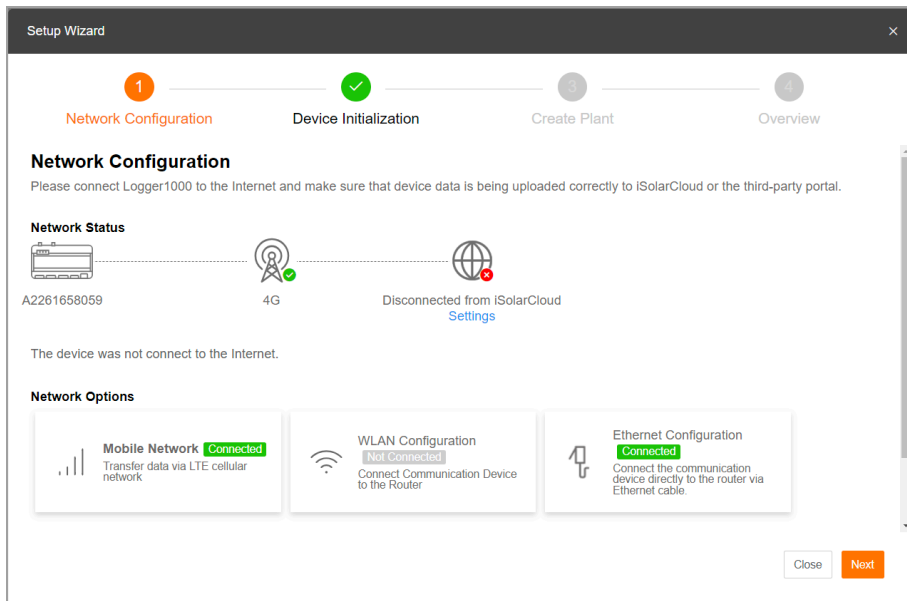

**step 1** Open the dialog **Setup Wizard** in one of the following ways:

- After the first login or following a reset of the Logger1000, the Web UI will automatically prompt the dialog **Setup Wizard**.
- On the page **Overview > General Information**, click **Shortcut Menu > Setup Wizard** to open the setup wizard.

**step 2** Configure the network.

The Logger1000 can be connected to the Internet in the following ways:

- **4G**: Confirm a SIM card is inserted, and click **Mobile Network** to establish a mobile network connection.
- **WLAN**: Click **WLAN Configuration**, and under the tab page **Client**, select an available wireless network and enter the password.
- **Ethernet**: Click **Ethernet Configuration**, and modify the Ethernet parameters as needed.



Only Logger1000A supports 4G communication methods.

**step 3** To enable remote web access for maintenance by O&M staff, check **Enable Remote Maintenance**.

**step 4** Click **Next** to proceed to the options **Device Initialization**.

**step 5** Set the system time.

- i. Next to the system time, click **Settings** to select a clock source.



During commissioning, it is recommended to synchronize with the local machine time using **User Define** .

- ii. Click **Save**.

**step 6** Click **Auto Search** to search for available SUNGROW inverters and add them to the system.

**step 7** Configure initial parameters for inverters.

- i. Click **Initial Parameter** to open the **Initial Parameter** dialog box.
- ii. In the drop-down list **Country/Region**, select the country where the power plant is located.
- iii. In the drop-down list **Start/Stop**, select the operation **Boot** to perform on the inverter.
- iv. Click **Settings** to apply the changes.

**step 8** Click **Next** to proceed to the options **Create Plant**.

**step 9** Follow the on-screen instructions, and complete the power plant, dealer or installer, and owner information.

A confirmation email will be sent to the designated address upon successful setup.

**step 10** Click **Next** to proceed to the options **Overview**.

In the option page **Overview**, you can review the basic configuration of the Logger1000.

**step 11** Click **Initial Report** to export and save the basic configuration locally.

**step 12** Click **Complete**.

-- End

You can switch between different usage scenarios for the Logger1000 by selecting the appropriate option in the upper right corner of the Web UI.

## 7.6 Selecting Usage Scenario of Web UI

After the initial setup, you must select the usage scenario of the Web UI based on actual needs and on-site situations.

### Prerequisites

- The user has O&M user permissions.
- Firmware version of the Logger1000: P036 or above. See [16.6 Viewing the Firmware Version](#).

Usage scenario	Corresponding option on the Web UI	Description
Data acquisition	<b>Data Logger</b>	The Logger1000 does not support energy management. This option is suitable for solar system.
Energy management	<b>Energy Management System</b>	The Logger1000 supports energy management. This option is suitable for energy storage system when integrated with SUNGROW storage inverters and batteries. For detailed instruction, see <a href="#">15 Energy Management</a> .

**step 1** In the upper right corner of the page, click the option displaying the usage scenario: **Data Logger** or **Energy Management System**.

The name of the option indicates the current scenario of the Web UI.

**step 2** In the drop-down list, select the desired usage scenario.

When the scenario **Energy Management System** is selected, new option **Energy Management** is added to the navigation bar.

- - End

## 8 Configuring Data and Network Interfaces

Configure parameters for interfaces and ports to facilitate seamless data exchange and network communication with connected devices.

Depending on the connection type, the following parameters can be configured:

- RS485
- Ethernet
- Mobile Network
- WLAN
- AI
- DI
- DO

Click **System > Port Parameter** in the navigation bar, from the expanded menu options, select the port type you wish to configure.

### 8.1 RS485 Communication Ports

To establish successful communication, confirm that the RS485 port settings on the Logger1000 align with those of the connected device.

**step 1** Click **System > Port Parameter > RS485** to navigate to the corresponding page.

**step 2** Select the serial port, and click  to open the **Advanced Settings** dialog box.

**step 3** Enter **Baud Rate**, **Parity Bit**, and **Stop Bit**.

The default configuration is 9600bps, 1 stop bit, and no check bit.

**step 4** Click **Save and Exit** to apply the changes.

-- End

### 8.2 Ethernet

Ensure proper device communication by configuring the Logger1000's network settings.



The default IP address of the ETH port is 12.12.12.12.





If both DHCP and WLAN client are enabled, they must be on different subnets to avoid conflicts.

- step 1** Click **System > Port Parameter > Ethernet** to navigate to the corresponding page.
- step 2** In the drop-down list **Automatically Obtain IP Settings DHCP**, select whether to allow the device to automatically obtain an IP address.
- step 3** If **Automatically Obtain IP Settings DHCP** is enabled, connect to the WLAN module and log in to 11.11.11.1 to view the ETH port's current IP.
- step 4** If **Automatically Obtain IP Settings DHCP** is disabled, manually modify network settings.

The following parameters can be configured:

- **IP Address**
- **Subnet Mask**
- **Default Gateway**
- **DNS1**
- **DNS2**

**step 5** Click  .

-- End

## 8.3 Mobile Network

Ensure that the Logger1000 can be correctly connected to the specified mobile network.

### Prerequisites

- The Access Point Name (APN) setup has been completed.



The VPDN SIM card must be configured with both public and private APN settings.

- step 1** Click **System > Port Parameter > Mobile Network** to navigate to the corresponding page.
- step 2** In the fields **Public Network APN** and **Private Network APN**, enter the respective Access Point Name names.
- step 3** Click  .

-- End

## 8.4 WLAN

Configure the wireless network settings for the Logger1000.

Tab	Description
<b>Client</b>	Used to configure if the Logger1000 should connect to other Wi-Fi hotspots or routers. The WLAN feature is enabled by default.
<b>Hotspot</b>	Used to configure if the Logger1000 should enable its built-in access point to share its mobile data connection with other devices. If <b>AP hotspot enable switch</b> is set to <b>Enable</b> , you can configure the following parameters <ul style="list-style-type: none"> <li>• <b>Network Name:</b> By default, the SSID is set to "SG-[device S/N]" and cannot be changed.</li> <li>• <b>Security</b> <ul style="list-style-type: none"> <li>- <b>None:</b> No password is required for connecting to the hotspot.</li> <li>- <b>WPA2:</b> Set a password to encrypt the network and control access.</li> </ul> </li> </ul>



If the WLAN hotspot password is changed, you must reconnect to the WLAN network.

**step 1** Click **System > Port Parameter > WiFi** to navigate to the corresponding page.

The **Client** tab page displays.

**step 2** Modify the network settings as needed.

-- End

## 8.5 Analog Input (AI) Port

The Logger1000 has 4 AI ports supporting functions such as active and reactive power control.

Tab	Description
<b>Built-in</b>	Set AI port parameters of the Logger1000
<b>External</b>	Set AI port parameters for external IO device connected to the Logger1000

**step 1** Click **System > Port Parameter > AI** to navigate to the corresponding page.

The **Built-in** tab page displays.

**step 2** Under **Input Type**, select the data type for the sampling signal of different AI ports.

- **Voltage**
- **Current**

**step 3** Depending on the data type, enter the upper and lower limits for the sampling signal in the **Lower Limit** and **Upper Limit** fields.

- Lower limit for voltage: 0~10 V. (Default value: 0)
- Upper limit for voltage: 0~10 V. (Default value: 10)
- Lower limit for current: 4~20 mA. (Default value: 4)
- Upper limit for current: 4~20 mA. (Default value: 20)

**step 4** In the field **Purpose**, describe what the AI port is used for.

**step 5** Click  .

**step 6** If the Logger1000 is connected to an external IO device via AI port, click **External** to set the related parameters.

-- End

## 8.6 Digital Inputs (DI) Port

The Logger1000 can be connected to various protective devices within the power plant via Digital Input (DI) ports. Examples of these devices include the Reverse Power Relay (RPR), Ground Fault Overvoltage Relay (OVGR), Undervoltage Protection Relay (UVR), and Earth Leakage Relay (ELR).

**table 8-1** Action description

Action	Inverted action
<b>Boot</b>	<b>Shutdown</b>
<b>Shutdown</b>	<b>Boot</b>
<b>Not Operated</b>	No command should be sent.

### Prerequisites



Before setting up the DI parameters, confirm the configurations of the protective devices:

- Normal operation status: **NO** or **NC**
- Status recovery mode: **Manual Control** or **Automatic Control**

**step 1** Click **System > Port Parameter > DI** to navigate to the corresponding page.

**step 2** Configure DI port parameters.

- i. Under **Initial Status**, select the status of this DI port during normal operation.
  - **NO**
  - **NC**
- ii. In the drop-down list **Inverter Action Triggered by DI Recovery**, select how the inverter should recover its status.
  - **Manual Control**: Manually restores the inverter's status.
  - **Automatic Control**: The Logger1000 issues a command to restore the inverter's status.
- iii. Under **Automatic Control**, in the field **Action Delay Time After DI Recovery**, specify the time interval for Logger1000 to wait before sending a command after receiving a DI status recovery signal.  
If no new DI signal change occurs within the set interval, the system will perform the defined inverted action of **Inverter Action Triggered By DI Action**.
- iv. In the drop-down list **Inverter Action Triggered By DI Action**, select the action for the Logger1000 to execute when the DI port status changes.
  - **Not Operated**: No command is sent to the inverter.
  - **Boot**: Power-on commands are sent to the inverter.
  - **Shutdown**: Power-off commands are sent to the inverter.
- v. In the field **Action Delay Time After DI Action**, set the time interval for the Logger1000 to wait before sending a command in response to a DI status change.  
If no new DI signal change occurs within the set interval, the system will perform the defined action **Inverter Action Triggered By DI Action**.
- i. In the field **Purpose**, describe what the DI port is used for.

**step 3** Click  .

-- End

## 8.7 Digital Output (DO) Port

The DO port parameters can be configured if an external IO module is used.

**table 8-2** Status Description

Status	Inverted Status
NO	NC
NC	NO

**step 1** Click **System > Port Parameter > DO** to navigate to the corresponding page.

**step 2** Configure DO port parameters.

- i. Under **Initial Status**, select the status of the DO port during normal operation.
  - **NO**
  - **NC**
- ii. In the drop-down list **Function**, select the method to control the DO port.
  - **Communication Control**: Send commands via iSolarCloud or a third-party device.
  - **Manual Control**: Manually control the status of the DO port via the Web UI.
- iii. In the drop-down list **Action Mode**, select the action after the DO port status changes.
  - **Level**: The DO port status remains changed.
  - **Pulse**: The DO port status returns to the initial status after holding the changed status for a period of time.
- iv. Only when **Action Mode** is set to **Pulse**, can you configure **Pulse Duration**.
- v. In the field **Purpose**, describe what the DO port is used for.

**step 3** In the mode **Manual Control**, set the corresponding parameters.

- i. In the upper right of the page, click **Manual Control**.
- ii. In the drop-down list **Control Method**, select the action after the DO status changes.
  - **Reset**: The DO port status returns to the initial status.
  - **Action** : The DO port status changes to the inverted status of **Initial Status**.
- iii. Click **Confirm**.

**step 4** Click  .

-- End

## 9 Configuring Data Communication and Transfer Protocols

Forward device data to the remote or local monitoring systems.

The following data communication and transfer methods are supported to transmit collected data to the designated monitoring system.

- iSolarCloud
- IEC104
- Modbus
- Third-party portal
- Echonet

**step 1** Click **System > Transfer Configuration** to navigate to the corresponding page.

By default, the iSolarCloud configuration page displays.

**step 2** Select a tab that suit your communication protocol, and configure the parameters accordingly.

-- End

### 9.1 Setting iSolarCloud Parameters

Transfer the collected data to iSolarCloud.



To ensure the Logger1000 can function properly, please complete the router whitelist settings first. For details, see [Router Whitelist Settings](#).

**step 1** Click the **iSolarCloud** tab.

**step 2** Turn on the switch to enable data transfer using iSolarCloud.

**step 3** Click  to open the **Advanced Settings** dialog box.

i. In the drop-down list **Server**, select the server according to the power plant's location.

- The default iSolarCloud server is a general server ([iot.isolarcloud.com](http://iot.isolarcloud.com)).
- Users in mainland China select "**Chinese Server**".
- Users in Europe select "**European Server**".
- Users in Australia select "**Australian Server**".
- Users in other regions select "**International Server**".

- ii. If there is no need to retrieve device data during nighttime, check **Night Silence** and set the start and end times.
- iii. Click **Save**.

-- End

## 9.2 Setting IEC104 Parameters

Transfer the collected data to the monitoring system using the IEC104 protocol.

- **Server Mode**

The Logger1000 acts as a server, responding to requests from client devices within the network.



The IEC104 protocol uses port 2404.

- **Client Mode**

The Logger1000 operates as a client that initiates requests and commands to the server devices.

### 9.2.1 IEC104 Forwarding Table

When using the IEC 104 communication protocol, a forwarding table needs to be configured to specify the data items and address information that need to be forwarded.

**table 9-1** Description of the forwarding table

Sheet	Description
Introduce	Explains the abbreviations for the five types of data: telemetry, telesignalling, remote pulse, remote control, and remote regulating.
Cfg Para	<ul style="list-style-type: none"> <li>• View and modify the beginning addresses of the five types of data (<b>Bngr Addr</b>).</li> <li>• The addresses displayed in the table are default and can be adjusted as needed based on the actual situation.</li> </ul>
Device List	<ul style="list-style-type: none"> <li>• View the devices. Related parameters can be configured.</li> <li>• The order of devices can be rearranged by dragging and dropping entire rows to the desired positions.</li> </ul>

Sheet	Description
Device's Name	Set the measuring data for devices such as inverter, Smart Energy Meter, Meteo Station, and Logger1000.

table 9-2 Device List sheet

Parameter	Description
Device Type	Device type
Com ID	The number of COM port to which device connected, corresponding to the information on the page <b>Device List</b> . The parameters should be set according to on-site conditions.
Collect ID	Collect device's Modbus address, corresponding to the communication address on the page <b>Device List</b> . The parameters should be set according to on-site conditions.
Access ID	The background access address, corresponding to the forwarding address on the <b>Device List</b> page. The parameters should be set according to on-site conditions.
Template Sheet	The name must match the corresponding name in the working sheet of the device.
Reserved YX Addr	Reserved tele-signaling address
Reserved YC Addr	Reserved telemetry address
Reserved YM Addr	Reserved remote pulse address
Reserved YK Addr	Reserved remote control address
Reserved YT Addr	Reserved remote regulating address

## 9.2.2 Setting IEC104 Parameters using Forwarding Table



To apply the default forwarding table settings to the 2404 port, click **Generate Point Table** .

To customize the forwarding table:

**step 1** Export the forwarding table.

- i. Select tab **Server**.
- ii. Turn on the switch for the port 2404.
- iii. Click **Export of Configuration Tools** to download the IEC104 forwarding point table locally.  
The forwarding table is in the .xslm format.

**step 2** Open the IEC104 forwarding table using Microsoft Excel, and make edits according to your on-site requirements.



**step 3** Save the forwarding table in Excel.

**step 4** Import the forwarding table.

i. In the Excel menu bar, select **IEC104 > IEC104 CFG**.

An Excel macro command will process and convert the .xslm file into a .xml file. The generated .xml file, along with the original .xslm file, will be located in the same file directory.

ii. Return to the web UI, navigate to the **IEC104 > Server** page, and click  to open the **Advanced Settings** dialog box.

iii. Under **Configuration File**, click , and follow the on-screen instructions to complete the import of the .xml file.

**step 5** Click **Save**.

-- End

### 9.2.3 Setting Communication Interruption Protection

If you're using the IEC104 protocol for communication with inverters, you can set restrictions on the power output ratio in case of communication failure.

**step 1** Navigate to the page **IEC104 > Server**, and click **Communication Interrupted Protection** to open the **Communication Interrupted Protection** dialog box.

**step 2** Set **Protection Switch** to **Enable**.

**step 3** Configure the following parameters.

- **Peer IP Address:** The IP address of the peer device.
- **Port:** The port number of the peer device.
- **Instruction Valid Period:** Specify the duration after which interrupted communication is considered abnormal.
- **Communication Abnormality Output:** Specify the percentage of power that should be dispatched during communication abnormalities.

**step 4** Click 

-- End

## 9.2.4 Restricting IEC104 Communication to Authorized Devices

To enhance security and control over the Logger1000, you can specify which devices are permitted to establish IEC104 protocol communication by creating a whitelist of approved IP addresses.

### Prerequisites

- The IP addresses of the specified devices are known.



If no whitelist is configured, the Logger1000 accepts connections from any valid IP address. The default IP address is 0.0.0.0.

**step 1** Navigate to the page **IEC104 > Server**, and click **White List Setting** to open the **White List Setting** dialog box.

**step 2** Check **Enable White List**.

**step 3** Under the column **Peer IP Address**, enter the IP addresses of the devices that are authorized.

**step 4** Click **Save**.

-- End

## 9.2.5 Adding a Peer Device

If a third-party device is added to function as a server, update the device information accordingly.

**step 1** Generate and edit the forwarding table.

See [9.2.2 Setting IEC104 Parameters using Forwarding Table](#).

**step 2** Return to the web UI, navigate to the **IEC104 > Client** page, and click  to open the **Advanced Settings** dialog box.

**step 3** Enter relevant information for the peer device.

- **Server:** Enter the domain name of the master station server.
- **Peer Port:** Enter the port number of the master station server.

Review and adjust any other settings to fit your requirements, or keep the default configurations if they suit your needs.

**step 4** Under **Configuration File**, click , and follow the on-screen instructions to complete the import of the .xml file.

**step 5** Click **Save**.

-- End

## 9.2.6 Configuring SSL Encryption

The ports used by the IEC104 forwarding service support SSL encryption. Users can enable or disable SSL encryption via the Web user interface.



This feature is available on LOGGER-SV300.001.00.P044 or later.

**step 1** Navigate to **System > Forwarding Configuration**, and click **IEC104**.

**step 2** Choose the **Server** tab. Here, you can enable or disable **SSL Encryption** for the local port.



Ports 2404 to 2418 are used for the IEC104 forwarding service. Port 2418 is enabled by default with SSL encryption activated. The other ports are disabled by default, and SSL encryption is also disabled. Users can manually enable or disable the port and SSL encryption.

If non-secure ports are used:

- If SSL encryption is enabled: When enabling the port manually, no security warning will appear.
- If SSL encryption is disabled: When enabling the port manually, a message will appear indicating that the protocol is insecure and risky. Verify that the device is operating on a secure network before enabling the port.
- When manually disabling SSL encryption for an enabled port: A message will appear stating that this protocol is risky. Verify that the device is operating on a secure network before disabling SSL encryption.
- When enabling SSL encryption for an enabled port: No security warning will appear.
- When the port is disabled: Actions on the SSL Encryption button will not trigger a security warning.

-- End

## 9.3 Setting Modbus Parameters

Transfer the collected data to the monitoring system using the Modbus protocol.

- **Server Mode**

The Logger1000 acts as a server, responding to requests from client devices within the network using the Modbus TCP protocol.

- **Client Mode**

The Logger1000 operates as a client that initiates requests and commands to the server devices using the Modbus TCP protocol.

- **RTU Mode**

The Logger1000 acts as a server, responding to requests from client devices within the network using the Modbus RTU protocol.



When Logger1000 (firmware version: P043 or later) works in "Server" or "RTU" mode, Address for Modbus Forwarding is required if the user wants to acquire data through third-party monitoring.

Click **Device > Device List** to navigate to the corresponding page. Obtain the forwarding address of the device in the **Address for Modbus Forwarding** column.

### 9.3.1 Setting Communication Interruption Protection

If you're using the Modbus protocol for communication with inverters, you can set restrictions on the power output ratio in case of communication failure.

**step 1** Navigate to the page **MODBUS > Server**, and click **Communication Interrupted Protection** to open the **Communication Interrupted Protection** dialog box.

**step 2** Set **Protection Switch** to **Enable**.

**step 3** Configure the following parameters.

- **Peer IP Address:** The IP address of the peer device.
- **Port:** The port number of the peer device.
- **Instruction Valid Period:** Specify the duration after which interrupted communication is considered abnormal.
- **Communication Abnormality Output:** Specify the percentage of power that should be dispatched during communication abnormalities.

**step 4** Click 

-- End

### 9.3.2 Restricting Modbus Communication to Authorized Devices

You can also specify which devices are permitted to establish Modbus protocol communication by creating a whitelist of approved IP addresses.

#### Prerequisites

- The IP addresses of the specified devices are known.

**step 1** Navigate to the page **MODBUS > Server**, and click **White List Setting** to open the **White List Setting** dialog box.

**step 2** Check **Enable White List**.

**step 3** Under the column **Peer IP Address**, enter the IP addresses of the devices that are authorized.

**step 4** Click **Save**.

-- End

### 9.3.3 Adding a Peer Device

If a third-party device is added to function as a server, update the device information accordingly.

**step 1** Navigate to the **MODBUS > Client** page, and click  to open the **Advanced Settings** dialog box.

**step 2** Enter relevant information for the peer device.

- **Server:** Enter the domain name of the master station server.
- **Peer Port:** Enter the port number of the master station server.

**step 3** Click **Save**.

-- End

### 9.3.4 Configuring Serial Port Parameters

When operating in Modbus-RTU mode, you can configure the serial port parameters to facilitate data communication and forwarding with third-party devices.

#### Prerequisites

- There are unoccupied COM ports can be configured.

**step 1** Click **MODBUS > RTU** to navigate to the corresponding tab page.

**step 2** In the drop-down list **Serial Port Name**, select the COM port to be configured.

If **Forwarding Is Prohibited** is selected, the Logger1000 will only collect data from the device connected to this port, and will not forward it.



A maximum of two COM ports can be used for data forwarding.

**step 3** In the field **Delay**, enter the desired time interval for the commands to be sent.

-- End

### 9.3.5 Configuring SSL Encryption

The ports used by the Modbus forwarding service support SSL encryption. Users can enable or disable SSL encryption via the Web user interface.



This feature is available on LOGGER-SV300.001.00.P044 or later.

**step 1** Navigate to **System > Forwarding Configuration**, and click **Modbus**.

**step 2** Choose the **Server** tab. Here, you can enable or disable **SSL Encryption** for the local port.



Ports 502 to 516 are used for the Modbus forwarding service. Port 516 is enabled by default with SSL encryption activated. The other ports are disabled by default, and SSL encryption is also disabled. Users can manually enable or disable the port and SSL encryption.

If non-secure ports are used:

- If SSL encryption is enabled: When enabling the port manually, no security warning will appear.
- If SSL encryption is disabled: When enabling the port manually, a message will appear indicating that the protocol is insecure and risky. Verify that the device is operating on a secure network before enabling the port.
- When manually disabling SSL encryption for an enabled port: A message will appear stating that this protocol is risky. Verify that the device is operating on a secure network before disabling SSL encryption.
- When enabling SSL encryption for an enabled port: No security warning will appear.
- When the port is disabled: Actions on the SSL Encryption button will not trigger a security warning.

-- End

## 9.4 Setting Parameters for Third-Party Portal

Transfer the collected data to a third-party monitoring system.

### Prerequisites

- There is an available FTP/SFTP server.

**step 1** Click the **Third-party Portal** tab.

**step 2** Turn on the switch to enable data transfer using an FTP or SFTP server.

**step 3** Click  to open the **Advanced Settings** dialog box.

**step 4** Update the configuration details.

The following parameters can be configured:

- **Server:** Enter the address or domain of the server.
- **Protocol Type:** Enter the protocol for data transfer.
  - **FTP:** Use the FTP protocol for standard data transfer scenarios.
  - **SFTP:** Use the SSH protocol for encrypted data transfer, suitable for scenarios requiring data security.
- **Peer Port:** Enter the communication port for the server. The default port for FTP is 21. The default port for SFTP is 22.
- **Account:** Enter the username or account to log in to the FTP/SFTP server.
- **Password:** Enter the password required for server access.
- **FTP Path:** Name the folder in the format “/FTP server directory”. For example, in “/SUNGROW”, “/” denotes the root directory, and “SUNGROW” is the directory on the FTP server where data is stored.
- **Sampling Cycle:** Determine the frequency of data collection from the Logger1000.
- **Transmission Cycle:** Specify how often data is uploaded to the FTP/SFTP server.
- **RFC3339:** Specify the timestamp format to use in data transfers.

**step 5** Click **Save**.

-- End

## 9.5 Setting Echonet Parameters

Transfer the collected data to the monitoring system using the Echonet protocol.



Click **Quick Configuration** to apply the default Echonet forwarding points for data forwarding.

**step 1** Click the **Echonet** tab.

**step 2** Turn on the switch to enable data forwarding using the Echonet protocol.

**step 3** Click  to export and download the default .xml file.

**step 4** Make the necessary edits to the .xml file and save the changes.

**step 5** Click  to open the **Advanced Settings** dialog box.

**step 6** Click  to import the .xml file.

**step 7** Click **Save**.

-- End

---

# 10 Device Administration

## 10.1 Adding SUNGROW Inverters

SUNGROW inverters can be automatically recognized on the Web UI, with unique addresses assigned to each inverter.

### Prerequisites

- The inverters can be identified by a serial number.
- The Logger1000 is correctly connected to the SUNGROW inverters.



If there is an address conflict, you will be prompted with a message.

**step 1** Navigate to the page **Device > Device List**, and click **Auto Search** to open the **Auto Search** dialog box.

**step 2** To view and filter inverters connected to a specific COM port, in the drop-down list **Port**, select the corresponding COM port.

-- End

## 10.2 Adding a Third-Party Device

### 10.2.1 Selecting Device

#### Prerequisites

- The Logger1000 is connected to the device.
- The port parameters of this device has been configured.

Take adding a third-party meter as an example:

**step 1** Navigate to the page **Device > Device List**, and click **Add Device** to open the **Add Device** dialog box.

**step 2** In the drop-down list **Device Type**, select the device type.



**step 3** In the drop-down list **Access Type**, select the meter type according to its actual installation location.

- **Electricity Meter**: Used to monitor power consumption on the inverter side.
- **Gateway Meter**: Used to monitor power consumption on the grid side.

**step 4** In the drop-down list **Port**, select the port that the meter is connected to.

-- End

## 10.2.2 Importing Device Information by Setting Measuring Points



For measuring point configuration templates, contact SUNGROW.

**step 1** In the drop-down list **Device Model**, select **Others**.

**step 2** In the drop-down list **Configuration Method**, select **Custom**.

**step 3** Click **Next** to open the **Configure Measuring Point** dialog box.

-- End

### 10.2.2.1 Verifying Measuring Point Data

Check the measuring points, and click **Read-back**.

If the values retrieved match the real-time display values from the third-party device, this confirms that the measurement points are configured correctly.

### 10.2.2.2 Saving Configuration as Template

By saving the previous modified measuring points configuration as a template, you enable a quicker and more efficient setup when dealing with third-party device settings in the future.

#### Prerequisites

- Ensure that the current measuring point parameters are configured.

**step 1** In the dialog **Configure Measuring Point**, click **Save Template** open the dialog.

**step 2** In the field **Template Name**, enter a descriptive name for the template.



The template name should be a combination of numbers, letters, dashes and underscores starting with English letters, with a maximum length of 32 bits.

**step 3** Click **Confirm** to save the template.

**step 4** In the dialog **Configure Measuring Point**, click **Confirm** to save the configuration of measuring points.

-- End

### 10.2.3 Importing Device Information Using a Configuration File

#### Prerequisites

- The device type and its corresponding connected port have been selected. See [10.2.1 Selecting Device](#).
- There are available measuring point configuration templates or a .xml configuration file.

**step 1** In the drop-down list **Device Model**, select **Others**.

**step 2** In the drop-down list **Configuration Method**, select **Import Files**.

**step 3** In the drop-down list **Configuration File**, select the relevant measuring point template, or click



to import the .xml configuration file.

**step 4** In the field **Beginning Address**, enter the beginning address of the device.

**step 5** In the field **Quantity of Device**, enter the number of devices added to the current port.



If multiple devices are added to the same port, ensure that the **Beginning Address** is greater than the existing ones to avoid conflicts.

**step 6** Click **Save**.

-- End

## 10.3 Configuring Device Parameters

### 10.3.1 Configuring Parameters for Inverters

View the inverter's real-time data and related parameters. You can adjust the settings of an individual inverter, or apply configurations to multiple inverters.

#### NOTICE

To maintain optimal performance and ensure safety, the inverter parameters must be configured by qualified personnel. Incorrect settings may lead to disconnection from the grid and impact energy yield.

#### NOTICE

Only SUNGROW inverter supports setting parameters via the Web UI.

Types of Parameters	Description
Initial Parameter	Select the country or region where the power plant is located.

Types of Parameters	Description
<b>Operation Parameters</b>	Used to adjust the inverter's performance and operational behavior.
<b>System Parameters</b>	Used to set the inverter's time.
<b>Protection Parameters</b>	Used to adjust standard protection measures and responses for general abnormal conditions.
<b>Protection Parameters (Others)</b>	Used to configure additional protections for specific abnormal scenarios.
<b>Power Regulation Parameters</b>	Used to adjust parameters related to grid dispatching.
<b>Energy Management Parameters</b>	Used to adjust parameters related to energy management. Only displayed for hybrid inverters.
<b>General Parameters</b>	Used for other general settings of the inverter.

**step 1** Click **Device Monitoring** to navigate to the corresponding page.

**step 2** From the device list on the left, select the inverter you wish to configure.

**step 3** Refer to the inverter's user manual and follow the on-screen instructions to adjust the inverter's operating parameters accordingly.

**step 4** Click **Settings** to apply the changes.

**step 5** Optional: Apply configurations to multiple inverters.

- i. Click **Configure Synchronization**.
- ii. Select the inverters you want to configure in the pop-up dialog, and click **Save**.

-- End

### 10.3.2 Configuring Parameters for Meter

**step 1** Click **Device Monitoring** to navigate to the corresponding page.

**step 2** From the device list on the left, select the meter you want to configure.

**step 3** On the right, select the tab page **Initial Parameter** to modify the meter's initial parameters.

- **PT Transformation Ratio:** Enter the turns ratio of the power transformer.
- **CT Transformation Ratio:** Enter the turns ratio of the current transformer.
- **Meter Reverse Connection Enable:** Use this setting if the meter cables are confirmed to be connected in reverse. It allows the meter to report accurate data. Both single-phase and three-phase meters can be configured for reverse connections. For three-phase meters, the setting is valid only if all three phases are reversed. Partial reverse connection (one or two phases) is not supported.
  - **Open:** The meter cables are currently connected in reverse.
  - **Close:** The meter cables are correctly connected.

- **Access Type** Select the meter type according to its actual installation location.
- **Meter Usage**: Select the meter's purpose based on its actual installation location and the usage scenario.

**step 4** Click **Settings** to apply the changes.

- - End

### 10.3.3 Configuring Parameters for Batteries

#### Prerequisites

- The SUNGROW inverter, equipped with a battery unit, is connected and operational.

**step 1** Click **Device Monitoring** to navigate to the corresponding page.

**step 2** From the device list on the left, select the battery associated with the inverter.

**step 3** Refer to the battery's user manual and follow the on-screen instructions to adjust the battery's operating parameters accordingly.

The following parameters can be configured:

- **Cut-off SOC of Discharge**: Specify the SOC level below which the battery should stop discharging.
- **Emergency Charging SOC**: Specify the SOC level below which the battery should begin forced charging.

**step 4** Click **Settings** to apply the changes.

- - End

### 10.3.4 Setting Meteo Sensor Parameters

**step 1** Choose **Device Maintenance** in the navigation bar.

**step 2** Select "Meteorological Sensor" from the device list on the left.

**step 3** Choose the **Initial Parameter** tab to modify the settings of initial parameters for the meteo sensor.

- **Instantaneous Horizontal Irradiance (W/m<sup>2</sup>)**: Select the AI port. Specify the upper and lower limits for instantaneous horizontal irradiance, in a range of 0 to 2000. The default value is 0.
- **Instantaneous Slope Irradiance (W/m<sup>2</sup>)**: Select the AI port. Specify the upper and lower limits for instantaneous slope irradiance, in a range of 0 to 2000. The default value is 0.
- **Ambient temperature (°C)**: Select the AI port. Specify the upper and lower limits for the ambient temperature, in a range of -100 to 100. The default value is 0.
- **Module temperature (°C)**: Select the AI port. Specify the upper and lower limits for the module temperature, in a range of -100 to 100. The default value is 0.



For LOGGER-SV300.001.00.P044 or later, you can configure the same parameter across multiple AI ports simultaneously. For example, you can configure the **Module Temperature** on A1, A2, A3, and A4 ports at the same time.

**step 4** Click **Save**.

-- End

### 10.3.5 Correcting Cumulative Power Generation

During operation, Rapid Shutdown Devices (RSDs) monitor the cumulative power generation data of the solar panels they are connected to. If an RSD fails and is replaced, the new device must be configured to continue monitoring data from the point recorded by the old device. O&M personnel can manually input and update the cumulative power generation data from the old device via the Web UI, ensuring continuity and accuracy of the data.

#### Prerequisites

- The RSD replacement has been completed.
- Firmware version of Logger1000: P042 or above.



When using the device replacement feature in iSolarCloud, the cumulative power generation data can be automatically corrected. For detailed instructions, see iSolarCloud App User Manual.

**step 1** Click **Device Monitoring** to navigate to the corresponding page.

Inverters connected to RSDs will be marked with an icon .

**step 2** In the device list on the left, select the connected RSD, then click the tab **RSD Parameter** on the right.

**step 3** In the field **PV Module Total Yield Adjustment**, enter the actual cumulative power respective module as recorded.

**step 4** Click **Settings** to apply the changes.

-- End

## 10.4 Automatic Frequency Point Assignment

Frequency point assignment involves assigning specific communication frequencies to devices to ensure that data is exchanged smoothly between them. Before connecting

inverters to the network, it helps prevent signal interference between devices, ensuring the accuracy of data acquisition.

### Prerequisites

Firmware version of Logger1000: P042 or above.

**step 1** Click **Device > Device List** to navigate to the corresponding page.

**step 2** Click **Automatic Frequency Point Assignment** to open the dialog box **Select Measuring Points**.

**step 3** From the drop-down menu, select the frequency points as indicated, ensuring they meet the required range and count.

**step 4** Click **Confirm**.

-- End

## 10.5 Uploading Physical Layout

In environments lacking network connectivity, it's essential for O&M personnel to upload the physical layout configurations of devices like inverters via the Web UI. This step ensures devices are correctly recognized and managed on the platform.

### Prerequisites

Firmware version of Logger1000: P042 or above.

**step 1** Click **Device > Device List** to navigate to the corresponding page.

**step 2** Click **Topology White List** to open the **Topology Information** dialog box.

**step 3** Download the template in .xlsx format to your local computer.

**step 4** Edit the layout template.

- i. Open this template with Excel and follow the provided instructions to fill out the device numbers and serial numbers (S/N).
- ii. Save your modifications.

**step 5** Upload the configuration.

- i. Return to the Logger1000's Web UI and in the dialog box **Topology Information**, click **Select File**.
- ii. Browse to the file location through the file explorer window that pops up and select the updated template file.
- iii. Click **Open** to upload the file and confirm the upload.
- iv. In the dialog **Topology Information**, click **Import**.

Once uploaded, the Web UI will automatically check the file for accuracy.

- v. If any errors are detected, refer to the on-screen prompts to make necessary corrections to the template file and upload it again.

-- End

## 10.6 Controlling SUNGROW Inverter

The Web UI enables you to remotely power SUNGROW inverters on or off and perform a reset.

### NOTICE

**Delivering a reset or shutdown to the inverter may lead to disconnection from the grid and impact energy yield.**

Take powering on the inverter as an example:

**step 1** Click **Device Monitoring** to navigate to the corresponding page.

**step 2** In the device list on the left, select the inverter, then click the tab **Device Instruction** on the right.

**step 3** Click **Boot** to open the dialog box.

**step 4** Click **Yes** to confirm and apply the power-on to the individual inverter.

**step 5** Optional: Batch powering on inverters.

- i. In the pop-up window, click **Configure Synchronization** to display the device list.
- ii. Select the inverters you want to power on, and click **Save**  
A dialog will appear to confirm the result.

-- End

## 10.7 Editing Device Information

**step 1** Click **Device > Device List** to navigate to the corresponding page.

**step 2** Click  to open the **Edit Device** dialog box.



**step 3** Modify the device information.

- **Device Name:** Edit the device name. The default naming convention is "Device model (port number-communication address)", such as "SG36KTL-M(COM1-7)".
- **Device Address:** The communication address of the device. It is only modifiable for SUNGROW inverter.

- **Address for Modbus Forwarding:** Integer, ranging from 1 to 246; used for data forwarding in Modbus TCP and Modbus RTU modes (this parameter is available for Logger1000 P043 or later).
- **Instruction Interval Time:** Specify the time interval between sending two consecutive commands.
- **Timeout Value:** Specify the maximum wait time for the device to respond to a command.
- **Repeat Times:** Specify the number of attempts to resend the command if a communication timeout occurs.

**step 4** Click **Save**.

**step 5** Optional: Batch modify names for multiple devices.

- Click  to download the general information of added devices locally. The file is in a .csv format.
- Edit the device names as needed.
- Click  to import the file.

-- End

## 10.8 Updating Devices

You can update the firmware for SUNGROW inverters.

### Prerequisites

Prepare the necessary files or configurations based on your chosen update method:

- Update locally
- Update online
- Update via iSolarCloud See [9 Configuring Data Communication and Transfer Protocols](#).



For the required tools and resource files for the update, contact SUNGROW.



The local update package must be in .zip or .sgu format.



The update process cannot be interrupted once it has begun.

**step 1** Click **Device > Firmware Update** to navigate to the corresponding page.

**step 2** Click **Select a Firmware File** to select an update method.

The following update methods are supported:



- **Local Update Package:** In the resource window, choose the firmware file and verify the matching devices.
- **Online Update Package:** Obtain the firmware package through the iConfig tool and proceed with the update.
- **iSolarCloud Upgrade Package:** Use the online firmware package available through iSolarCloud to update the device.

**step 3** Follow the on-screen instructions to complete the update process.

-- End

After updating, you can view details such as the current firmware version, target version number, and the time of the update.

## 10.9 Removing Devices

If the device is no longer needed on site, remove it on the web UI.

**step 1** Click **Device > Device List** to navigate to the corresponding page.

**step 2** Check the device to be deleted, and click **Delete**.

**step 3** In the pop-up dialog, click **Confirm**.

-- End

## 10.10 Enabling Arc Fault Circuit Interrupter (AFCI) Function

### Prerequisites

- The currently added inverters support self-checks.

**step 1** Click **Device > AFCI Activation** to navigate to the corresponding page.

**step 2** In the drop-down list **Status**, set the status to **Enable** to enable the self-check.

**step 3** In the pop-up dialog, select **Settings** to confirm to enable self-checking.

**step 4** Check the inverters you wish to set for self-checking, and click **Self Checking**.

**step 5** In the pop-up dialog, click **Confirm**.

The self-check status will be updated to "Self-Testing".

**step 6** If the self-check status is updated to "Self-checking Failure", click **Clear Fault**.

-- End

# 11 Device Monitoring

## 11.1 Viewing Power Plant and Device Operation Information

### Power Plant Operation

On the page **Overview > General Information**, you can view the basic information of the power plant.

- **Data Index:** Displays crucial operational data such as today's energy production, total energy production, and real-time active power output.
- **Inverter Real-time Values:** Displays the status and performance metrics of the inverter equipment.

### Device Information



On the page **Device Monitoring**, you can view the basic information of devices.

Depending on the type of connected device, you can access various information:

- **Realtime Values**
- **DC Info**
- **Device Information**
- **Battery Information**

On the page **Device Monitoring** or **Device > Device List**, you can view the communication status of the device.

**table 11-1** Device communication status

Icon	Description
	Device communication is normal.
	Device communication is abnormal



The device data will be cached for 7 days. In the case of network outage during the operation of the device, the inverter data generated during the period of network outage will be uploaded after the network service is back to normal. Contact SUNGROW if you want to check the data uploaded after the network outage event.

## 11.2 Viewing Alarms

Click **Overview > Current Alarms** to navigate to the corresponding page.  
Monitor the live status of alarm events.

---

# 12 Exporting Data

## 12.1 Exporting Logs of Connected Devices

The Web UI supports exporting logs from inverters.

### Prerequisites

- The status of the device must be “connected”.

**step 1** Click **Device > Inverter Log** to navigate to the corresponding page.

**step 2** In the drop-down list on the upper-left corner, select the device type.

**step 3** Check the devices, and click  .

A dialog displays to indicate the progress of the export.

**step 4** When the export progress reaches “100%”, click **Export** to export the logs locally.

-- End

## 12.2 Exporting Logs of Logger1000

**step 1** Click **System > System Maintenance** to navigate to the corresponding page.

**step 2** Click **Log Export** to open the **Log File Type Selection** dialog box.

**step 3** Select the type of logs to you wish to export.

The following types are supported.

- **Commissioning Log**
- **Operation Log**
- **History Data**
- **Scheduling Logs**

**step 4** Click **Confirm** to export the logs locally.

-- End

## 12.3 Exporting Communication Packets

The Logger1000 can capture and export communication packets from various ports. This helps diagnosing issues with connected devices or the Logger1000 itself.

**step 1** Click **System > Message Export** to navigate to the corresponding page.

**step 2** In the drop-down list **Port**, select the port type you wish to capture packets from.

- **Serial Port**: Receive or log packet data from the RS485 port.
- **Network Port**: Receive or log packet data from the network interface.

**step 3** If **Serial Port** is selected, in the drop-down list **Serial Port**, select the COM port for data capture.

**step 4** If **Network Port** is selected, in the drop-down list **Network Port**, select the method of network connection for data capture.

**step 5** In the field **Duration**, set the time period for which you want to log the packets.

**step 6** Click **Start** to start logging the packets.

The packet logging automatically stops at the end of the set time.

**step 7** Optional: To manually stop logging the packets, click **Stop**.

**step 8** Click **Export** to export and download the logged data locally.

-- End

## 12.4 Exporting Fault Recorder Data

**step 1** Click **Device > Fault Recorder** to enter the corresponding page.

**step 2** Select the device, and click  to export the data locally.

**step 3** Extract the contents of the compressed file to a local directory.

**step 4** Open the .txt file using iConfig to review the fault records of the device.



For the installation package and instructions of iConfig, contact SUNGROW customer service.

-- End

## 13 Power Control (PV System)

### NOTICE

Power control is available only when the inverter supports active power control, power factor control, and reactive power regulation!

For details, refer to the inverter user manual or consult the local retailer.

### 13.1 Function Description

The Logger1000 can regulate power output to the connected inverter.

- Supports control of the SUNGROW inverter's power output.
- Supports closed-loop power regulation, with improved accuracy and real-time performance achievable through the use of a meter.
- Supports rapid command transmission channels with millisecond-level processing delays, while ensuring accurate delivery of dispatch commands to all inverters.
- Supports control of power output according to locally preset commands.
- Supports regulation commands via remote communication protocols (IEC104, MODBUS, and TCP), analog inputs (AI), and dry contact inputs (DI).

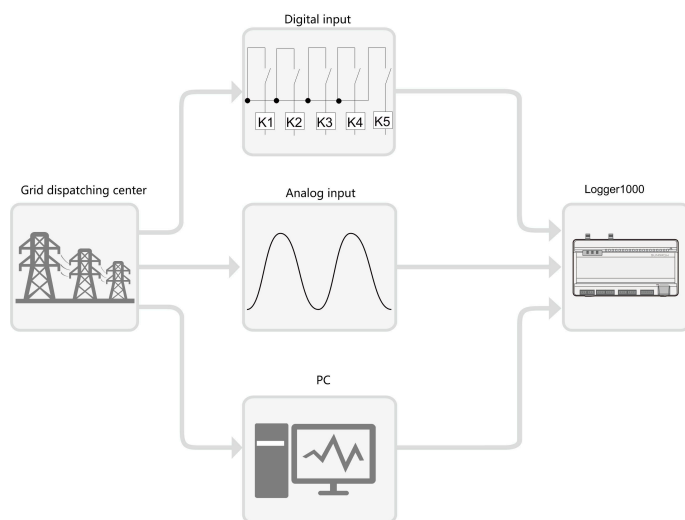

figure 13-1 System structure for the power control function

## 13.2 Interface Description

The Logger1000 is equipped with digital control interfaces and analog control interfaces for receiving digital and analog signals sent by the grid dispatching center.

### 13.2.1 Digital Control Interface

- The analog control interfaces are at the bottom of Logger1000. There are five ports dedicated to digital inputs.
- There are also 4 ports labeled as "AI/DI" that can serve as either analog or digital inputs. To configure the "AI/DI" ports for digital input, a power cable should be connected from the "24V OUT+" port to the "DI" port.



figure 13-2 Digital Control Interface

table 13-1 Digital control interface signal definition

Signal	Definition
DI	Enables the switch of AI ports to function as DI ports.
1+, 1-, 2+, 2-, 3+, 3-, 4+, 4-	4 input channels for dry contact signals.
1, 2, 3, 4, 5	5 digital input channels for dry contact signals. The DI5 port is used for connecting the emergency stop device.
DRM	Works together with DI1 to DI4 ports to implement the Demand Response Management (DRM) function.
0V	Grounding point for emergency stop device.



In Germany and some other European countries, grid companies use Ripple Control Receiver to convert grid dispatching signals and transmit them through dry contacts. In this case, the power plant needs to receive the grid dispatching signals through dry contact communication.

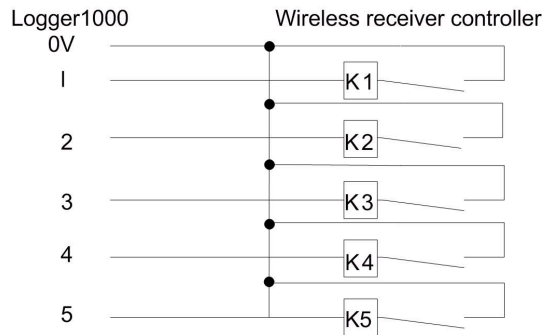

**figure 13-3** Circuitry overview of the connection to a wireless remote controller

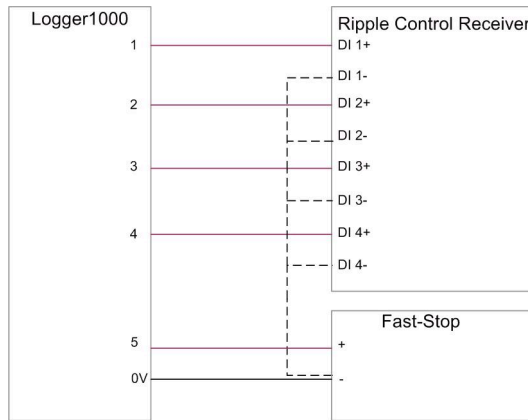

**figure 13-4** Circuitry overview of the connection to active power dry contact

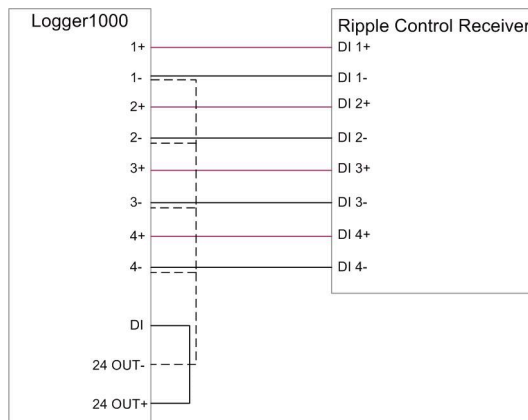

**figure 13-5** Circuitry overview of the connection to reactive power dry contact



### 13.2.2 Analog Control Interface

- The analog control interfaces are at the bottom of Logger1000, and a total of 4 analog input ports are provided.
- The Logger1000 supports 4 analog inputs, either 4-20mA for current or 0-10V for voltage.

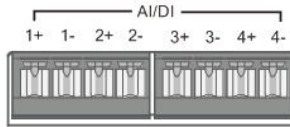

figure 13-6 Analog Control Interface

table 13-2 Analog control interface signal definition

Signal	Definition
1+ , 1- , 2+ , 2- , 3+ , 3- , 4+ , 4-	4 analog input channels

### 13.2.3 DRM Control Interface

- The DRM control interface are located at the bottom of Logger1000.
- The DRM interface works together with the DI1 to DI4 ports to implement the DRM function.
- To enable the DRM function, the Logger1000 must connect to a Demand Response Enabling Device (DRED). The connection can be established via wiring terminals or RJ45 connector.

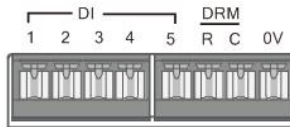

figure 13-7 DRM Control Interface

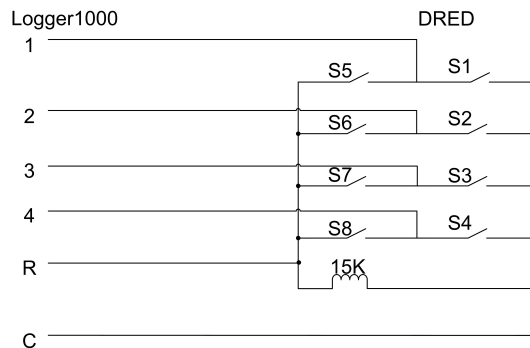

figure 13-8 Circuitry overview of the connection to the DRED

### 13.3 Options for Power Control Method

When adjusting active or reactive power, you can select between two control method: open-loop or closed-loop.

#### Open-Loop Control

Open-loop control does not rely on feedback from the inverter's actual output. Once the Data Logger sends the initial power control command, no further adjustments are made based on the inverter's output. This control method is suitable for scenarios that require quick adjustments.

#### Closed-Loop control

Closed-loop control depends on feedback from the inverter's actual output. The Data Logger continuously monitors the inverter's output power and compares it to the target power. If any deviation is detected, the Data Logger automatically adjusts the control commands to ensure accuracy and stability in output power. This control method is ideal for scenarios that require precise power adjustments.



To ensure accurate data feedback, closed-loop control requires connecting an smart energy meter or a box transformer with a control device to the Data Logger.

### 13.4 Selecting Power Control Mode

Both active power limitation and reactive power adjustment support various control methods. You can select based on the scale and needs of your power station.

Mode	Description
<b>Remote Power Control</b>	Remotely control the photovoltaic power generation. Recommended for scenarios requiring power adjustment through PPC (Power Plant Controller) or AGC (Automatic Generation Controller).
<b>Local Power Control</b>	Directly control the inverter's photovoltaic power via the Data Logger. This method is suitable for distributed power stations and zero-feed-in scenarios. Recommended when the power station is in a commissioning phase.
<b>Analog Input</b>	Use digital signals from the Data Logger's AI port (e.g., current or voltage) to adjust inverter power.
<b>Digital Input</b>	Use digital signals from the Data Logger's DI port, typically for responding to dry contact signals.

Mode	Description
<b>DRM Mode</b>	Demand Response Management (DRM) is a method for controlling power consumption that adjusts the load in response to signals from the power grid.
<b>Country Mode</b>	Suitable for meeting specific national or regional grid requirements.
<b>Disable Dispatching</b>	Select this option when the power adjustment has started and the inverter needs to maintain its current state.
<b>Disable Derating</b>	Recommended for scenarios where the inverter needs to maintain maximum power output. For example, during peak energy demand periods, this option ensures active power output is not reduced due to power adjustment. Only supports active power control.
<b>Disable Output</b>	Recommended for scenarios where the inverter needs to stop reactive power output. Only supports reactive power control.

#### Prerequisites

- The web UI has switched to the data acquisition scenario.

**step 1** Click **Power Control** in the navigation bar, from the expanded menu options, select **Active Power** or **Reactive Power**.

**step 2** On the page **Active Power** or **Reactive Power**, in the drop-down list **Active Control Mode** or **Reactive Control Mode**, select the desired power control method.

-- End

## 13.5 Settings for Active Power Control

#### Prerequisites

- The web UI has switched to the data acquisition scenario.

Click **Power Control > Active Power** to navigate to the corresponding page.

### 13.5.1 Remotely Regulating Active Power

Select the monitoring backend that uses the IEC104 or MODBUS TCP protocol as the source of dispatch commands.

Once the remote dispatch configuration is complete, users can send dispatch commands through the monitoring backend.

### 13.5.1.1 Open-Loop Control

#### Prerequisites

- The **Active Control Mode** is currently set to **Remote Power Control**. Refer to [13.4 Selecting Power Control Mode](#).

**step 1** In the drop-down list **Control Method**, select **Open-loop Control**.

**step 2** In the field **Query Recovery Time**, specify the time to pause data interaction between the Logger1000 and the inverter.

When power adjustment starts, the Logger1000 temporarily stops regular data reading to prioritize adjusting the inverter's power output for quick and accurate control.

For example, if **Query Recovery Time** is set to "60," the Logger1000 will not collect data from the inverter for 60 seconds after the power adjustment command is received. This might cause a delay in viewing device data via the Web UI or cloud platform during this period.

**step 3** In the field **Frame Delay**, specify the frame interval for the Logger1000 to read inverter data.

**step 4** Click **Save**.

-- End

Once the configuration is complete, you can send further power control commands through the backend.

### 13.5.1.2 Closed-Loop Control

#### Prerequisites

- The current **Active Control Mode** is set to **Remote Power Control**. Refer to [13.4 Selecting Power Control Mode](#).
- A gateway meter or a box transformer with monitoring and control devices is connected.

**step 1** In the drop-down list **Control Method**, select **Closed-loop Control**.

**step 2** In the drop-down list **Select energy meter/transformer**, select the meter or transformer for power regulation.

**step 3** In the drop-down list **Control Cycle**, specify the interval at which the Logger1000 sends dispatch commands to the inverter.

**step 4** In the field **Error Limit**, specify the allowable error range for the ratio between the difference in actual active power and the target value, relative to the rated power.

If the ratio is within the error range, the power adjustment is considered to have reached the target value. You should adjust this parameter in real-time based on the inverter's output power.

**step 5** In the field **Adjustment Ratio**, set the ratio between the inverter's output power and the target value.

If the adjustment result does not reach the set target value, the Logger1000 will adjust according to the set adjustment ratio to achieve the target value. You should adjust this parameter in real-time based on the inverter's output power.

**step 6** Click **Save**.

-- End

Once the configuration is complete, you can send further power control commands through the backend.

## 13.5.2 Locally Regulating Active Power

Configure the parameters for local active power control.

### 13.5.2.1 Open-Loop Control

#### Prerequisites

- The **Active Control Mode** is currently set to **Local Power Control**. Refer to [13.4 Selecting Power Control Mode](#).

**step 1** In the drop-down list **Control Method**, select **Open-loop Control**.

**step 2** In the drop-down list **Control Cycle**, specify the interval at which the Logger1000 sends dispatch commands to the inverter.

**step 3** In the drop-down list **Instruction Type**, select the designated unit for power regulation.

- **kW**: Adjusts the power by setting the total rated power of the inverter array. Recommended for scenarios where precise control of the inverter's output power is required, such as when a power station needs to comply with grid capacity limits.
- **%**: Adjusts power based on a percentage of the inverter's maximum rated power. Recommended for scenarios where the output needs to be adjusted according to the inverter's capacity.

**step 4** Click **Save**.

-- End

After configuration, specify the time and target values for local power control. Refer to [13.5.2.3 Configuring Adjustment Time and Target Values](#).

### 13.5.2.2 Closed-Loop Control

#### Prerequisites

- The current **Active Control Mode** is set to **Local Power Control**. Refer to [13.4 Selecting Power Control Mode](#).
- For closed-loop control, a gateway meter for power control must be connected.

**step 1** In the drop-down list **Control Method**, select **Closed-loop Control**.

**step 2** In the drop-down list **Select energy meter/transformer**, select the meter or transformer for power regulation.

**step 3** When the communication with the meter is interrupted, configure the relevant parameters of the Logger1000.

- i. In the field **Power Limit in Case of Meter Communication Anomaly**, specify the target value as a percentage to be issued by the Logger1000 when there is a communication failure with the meter.

When **Power Limit in Case of Meter Communication Anomaly** is set to "0%", the Logger1000 will send a shutdown command to the inverter after confirming the communication failure with the meter.

- ii. When the inverters are shut, in the drop-down list **Start After Communication Recovery**, select whether the Logger1000 should send a power-on command to the inverters when communication with the meter resumes.

- **Enable**: When the communication resumes, the inverter will restart.
- **Disable**: When the communication resumes, the inverter will remain shut down.

- iii. In the field **Start Delay After Communication Recovery**, specify the waiting time for the Logger1000 to send a power-on command to the inverter after communication is restored.

**step 4** If zero power feed-in is required, in the drop-down list **Wiring Mode**, select the connection mode of the Logger1000 based on the actual situation.

- **Direct Connection**: The Logger1000 establishes direct connections with all string or central inverters.
- **Cascading**: Multiple Logger1000s are interconnected in a cascading manner, with this particular Logger1000 as the master unit within the network.

**step 5** In the drop-down list **Feed-in Stop**, select whether the Logger1000 should send a shutdown command to the inverter when grid power feed-in is detected.

- **Enable:** The inverter will shut down when feed-in power is detected by the meter. Select this option when zero power feed-in is required.



After the inverter shuts down, if the meter detects that the power draw exceeds 10% of the system's rated power, the Logger1000 will send a power-on command to the inverter.

- **Disable:** The inverter will remain on even when feed-in power is detected by the meter.

**step 6** In the drop-down list **Feed-in Control Mode**, select the grid control mode according to the type of data the meter collects.

- **Total Active Power Control:** The meter collects three-phase data on the grid side as the feedback value for regulation.
- **Split Phase Active Power Control:** The meter collects single-phase data as the feedback value for regulation.

**step 7** In the field **Energy Meter Response Time**, based on the model of the connected meter, adjust the meter response time, to improve grid feed-in speed and precision.

**step 8** In the field **Over-scaling**, enter the desired value for over-scaling.

Based on the initial power limit target, Logger1000 will adjust the inverter's output once to ensure it stays below the set limit, without the need for repeated adjustments. It is recommended to use this parameter in scenarios that require stringent power control, such as anti-backflow or achieving zero power feed-in.

**step 9** In the drop-down list **Control Cycle**, specify the interval at which the Logger1000 sends dispatch commands to the inverter.

**step 10** In the drop-down list **Instruction Type**, select the designated unit for power regulation.

- **kW:** Adjusts the power by setting the total rated power of the inverter array. Recommended for scenarios where precise control of the inverter's output power is required, such as when a power station needs to comply with grid capacity limits.
- **%:** Adjusts power based on a percentage of the inverter's maximum rated power. Recommended for scenarios where the output needs to be adjusted according to the inverter's capacity.

**step 11** When **kW** is selected, set a reasonable feed-in power value according to local regulations.

**step 12** When % is selected, in the drop-down list **Feed-in Limitation Method**, select a reference for limiting the grid-connected power.

- **Nominal Power:** Calculate the value to be sent for power control based on the inverter's rated power.
- **Installed PV Power:** Calculate the value to be sent for power control based on the installed PV capacity. Enter the total installed power of PV modules at the power plant.

**step 13** Click **Save**.

-- End

After configuration, specify the time and target values for local power control. Refer to [13.5.2.3 Configuring Adjustment Time and Target Values](#).

### 13.5.2.3 Configuring Adjustment Time and Target Values

#### Prerequisites

- The selected power control strategy and related configurations are complete.

The specific time and target values for local power control is presented in a table.

<input type="checkbox"/>	Start Time	Percentage
<input type="checkbox"/>	00:00	
<input type="checkbox"/>		
<input type="checkbox"/>		
<input type="checkbox"/>		
<input type="checkbox"/>		
<input type="checkbox"/>		
<input type="checkbox"/>		
<input type="checkbox"/>		
<input type="checkbox"/>		
<input type="checkbox"/>		



If no additional combinations of time and target values are set, the Logger1000 will adjust power according to default values throughout the day.

**step 1** Position the cursor in the column **Start Time**, and in the time picker, select the time to deliver the power control command.

Time is precise to the minute. The default power adjustment starts at "00:00" and cannot be changed.

**step 2** Depending on the selected **Instruction Type**, enter the target value for active power in the corresponding column **Fixed Value of Active Power** or **Percentage**.





To meet zero power feed-in or anti-backflow requirements, set the target value to "0", indicating that the inverter will not output any active power to the grid.

However, to strictly control feed-in power and handle load fluctuations, it is recommended to set the target value to a negative number. After configuration, the load will draw power from the grid instead, ensuring the inverter does not active power is fed into the grid.

**step 3** To delete a specific adjustment time and target value, check the corresponding box in the first column, and click **Clear Data**.

**step 4** Click **Save**.

-- End

### 13.5.3 Regulating Active Power via Analog Input

#### Prerequisites

- The **Active Control Mode** is currently set to **Analog Input**. Refer to [13.4 Selecting Power Control Mode](#).
- For closed-loop control, a gateway meter for power control must be connected.
- Certain parameters are only configurable when the IOM424 module is connected.

**step 1** In the drop-down list **Control Method**, select **Open-loop Control** or **Closed-loop Control**.

**step 2** For **Closed-loop Control**, in the drop-down list **Select energy meter/transformer**, select the meter or transformer for power regulation.

**step 3** In the drop-down list **Control Cycle**, specify the interval at which the Logger1000 sends dispatch commands to the inverter.

**step 4** In the drop-down list **AI Port**, select the AI port that accepts the analog input signals. To configure the AI port parameters, click **AI Configuration** to navigate to the **System > Port Parameter > AI** page.

**step 5** In the drop-down list **Instruction Type**, select the designated unit for power regulation.

- **kW**: Adjusts the power by setting the total rated power of the inverter array. Recommended for scenarios where precise control of the inverter's output power is required, such as when a power station needs to comply with grid capacity limits.
- **%**: Adjusts power based on a percentage of the inverter's maximum rated power. Recommended for scenarios where the output needs to be adjusted according to the inverter's capacity.

**step 6** Depending on the **Instruction Type**, in the field **Min** and **Max**, set the target value range for power control.

- When **Instruction Type** is set to **%**, the range of **Min** and **Max** is 0 to 100%.
- **Instruction Type** When selecting **kW**, the range of **Min** and **Max** is 0.0 kW to 999999.9 kW.

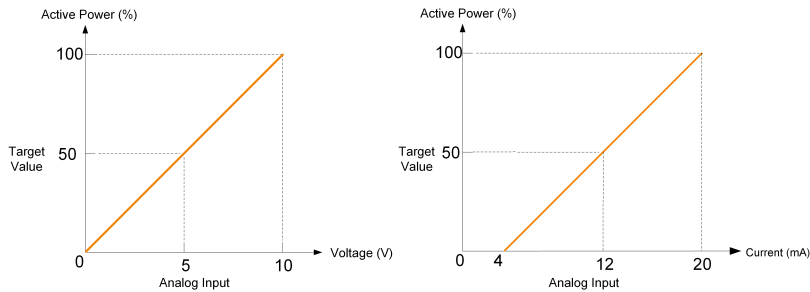

**figure 13-9** Example of the relationship between analog input values and target values

**step 7** Depending on **Instruction Type**, in the field **Step**, set the minimum difference value between two consecutive power control commands.

**step 8** When **Open-loop Control** is selected, configure the following parameters.

- In the **Sampling Value Less Than Lower Limit Power Value** field, enter the power limit ratio to be sent when the sampled value from the AI channel is below the lower limit.
- In the drop-down list **Sampling Value Less Than Lower Limit Associated DO**, select the associated DO port.  
If the sampled value from the AI channel falls below the lower limit, this DO port will be activated to perform the specified action.
- In the field **Sampling Value Less Than Lower Limit Fault Recovery Time**, set the time required for the DO port to restore to the initial state when the sampled value from the AI channel falls below the lower limit.
- In the **Sampling Value Greater Than Upper Limit Power Value** field, set the power limit ratio to be sent when the sampled value from the AI channel exceeds the upper limit.

v. In the drop-down list **Sampling Value Greater Than Upper Limit Associated DO**, select the associated DO port.

If the sampled value from the AI channel exceeds the upper limit, this DO port will be activated to perform the specified action.

vi. In the field **Sampling Value Greater Than Upper Limit Fault Recovery Time**, set the time required for the DO port to restore to the initial state when the sampled value from the AI channel exceeds the upper limit.

**step 9** Click **Save**.

-- End

### 13.5.4 Regulating Active Power via Digital Input

#### Prerequisites

- The **Active Control Mode** is currently set to **Digital Input**. Refer to [13.4 Selecting Power Control Mode](#).
- For closed-loop control, a gateway meter for power control must be connected.

**step 1** In the drop-down list **Control Method**, select **Open-loop Control** or **Closed-loop Control**.

**step 2** For **Closed-loop Control**, in the drop-down list **Select energy meter/transformer**, select the meter or transformer for power regulation.

**step 3** In the drop-down list **Control Cycle**, specify the interval at which the Logger1000 sends dispatch commands to the inverter.

**step 4** In the drop-down list **Instruction Type**, select the designated unit for power regulation.

- **kW**: Adjusts the power by setting the total rated power of the inverter array. Recommended for scenarios where precise control of the inverter's output power is required, such as when a power station needs to comply with grid capacity limits.
- **%**: Adjusts power based on a percentage of the inverter's maximum rated power. Recommended for scenarios where the output needs to be adjusted according to the inverter's capacity.

**step 5** When **Closed-loop Control** is selected, and the unit for target value is set to **%**, in the drop-down list **Feed-in Limitation Method**, specify a reference for limiting the grid-connected power.

- **Nominal Power**: Calculate the value to be sent for power control based on the inverter's rated power.
- **Installed PV Power**: Calculate the value to be sent for power control based on the installed PV capacity. Enter the total installed power of PV modules at the power plant.

**step 6** In the table at the bottom of the page, set the target values for power control corresponding to the digital input signals.

- i. Based on the dry contact signals received by the DI ports, check the corresponding DI port.
- ii. Depending on the **Instruction Type**, enter a fixed value or a percentage for active power control.



To delete the DI signal configuration, select the checkbox in the first column of the row, and click **Clear Data** .

**step 7** Click **Save**.

-- End

### 13.5.5 Regulating Power via DRM

#### Prerequisites

- The **Active Control Mode** is currently set to **DRM Mode**. See [13.4 Selecting Power Control Mode](#).

**step 1** When selecting DRM mode, check the box **Whether it coexists with other active control modes** according to actual requirements.

**step 2** Click **Save**.

-- End

### 13.5.6 Regulating Active Power via Country Mode

Implement power regulations according to the commands issued by the national grid dispatching center.

#### 13.5.6.1 Korea

**step 1** In the drop-down list **Country**, select **Korea**.

**step 2** In the drop-down list **PPC Type**, select the power plant controller DER-AVM.

**step 3** In the field **Forwarding Modbus ID**, enter the Modbus forwarding address (Range: 1~10).

**step 4** Click **Save**.

-- End

#### 13.5.6.2 Japan

**step 1** In the drop-down list **Country**, select **Japan**.

**step 2** In the drop-down list **Control Method**, select **Open-loop Control** or **Closed-loop Control**.

**step 3** When **Closed-loop Control** is selected, click **Closed-loop Control Parameters** to modify the closed-loop control related parameters.

The following parameters can be configured:

- **Select Meter**
- **Wiring Mode**
- **Feed-in Control Mode**
- **Energy Meter Response Time**
- **Over-scaling**
- **Active Power Change Rate**:: The rate of change of active power over time. Used to control the acceleration and deceleration of active power to prevent sudden power changes from impacting the grid.
- **Control Cycle**

**step 4** In the drop-down list **Scheduling Mode**, select the required power company for the power plant. The Logger1000 will connect to the dispatch server designated by the power company.

**step 5** In the drop-down list **Obtaining Schedule**, select the method to retrieve the dispatch schedule.

- **Remote Download**: Download the schedule through the server address. The ID of the power plant must be entered.
- **Local Import**: Manually upload the schedule.

**step 6** In the drop-down list **Parameter Type**, select the type of the parameters.

- **Plant Parameter** : Both **Plant Information** and **PV Module Capacity** must be set.
- **Device Parameter** : Click **Detailed Device Parameter** to view and set the device's detailed information.

**step 7** In the drop-down list **Time Calibration**, select the number of minutes to adjust the current time.

Select a positive value to advance the time, or select a negative value to set the time back.

The field **Time Validity** displays the time calibration result.

If it displays **Invalid**, the Logger1000 sends a shutdown command to the connected inverters, until the time is correctly calibrated or synchronized.

The time calibration may not be valid for the following reasons:

- The Logger1000 system time is earlier than the calibrated time
- The Logger1000 system time is earlier than the time synchronized via NTP

**step 8** Click **Save**.

-- End

### 13.5.7 Disabling Active Power Control

If the Logger1000 has already limited the inverter's active power and you need the inverter to maintain its current state, you can disable active power control.

**step 1** On the **Active Power** page, set **Active Control Mode** to **Disable Dispatching**.

**step 2** Click **Save**.

- - End

Once the settings are completed, the inverter will continue to operate with the current active power adjustment limit.

### 13.5.8 Prohibiting the Inverter from Reducing Power Output

**step 1** On the **Active Power** page, set **Active Control Mode** to **Disable Derating**.

**step 2** Click **Save**.

- - End

Once the settings are completed, the Logger1000 will stop limiting active power, and the inverter will operate at full load, maintaining an output power level of "100%".

## 13.6 Settings for Reactive Power Control

### Prerequisites

- The web UI has switched to the data acquisition scenario.

Click **Power Control > Reactive Power** to navigate to the corresponding page.

### 13.6.1 Remotely Regulating Reactive Power

#### Prerequisites

- The **Reactive Control Mode** is currently set to **Remote Power Control**. Refer to [13.4 Selecting Power Control Mode](#).
- For closed-loop control, a gateway meter or a box transformer with monitoring and control devices must be connected.

**step 1** In the drop-down list **Control Method**, select **Open-loop Control** or **Closed-loop Control**.

**step 2** When **Open-loop Control** is selected, refer to the remote active power control and configure the corresponding parameters. Refer to [13.5.1.1 Open-Loop Control](#).

**step 3** When **Closed-loop Control** is selected, refer to the remote active power control and configure the corresponding parameters. Refer to [13.5.1.2 Closed-Loop Control](#).

**step 4** When **Closed-loop Control** is selected, in the drop-down list **Reactive Power Direction**, select whether the reactive power output direction recorded by the meter or transformer matches the inverter.



By default, the SUNGROW inverter outputs inductive reactive power (positive) when the grid needs to increase voltage, and capacitive reactive power (negative) when it needs to decrease voltage.

- **Forward Direction:** The reactive power direction recorded at the grid connection point matches the inverter's reactive power direction.
- **Direction Reverse:** The reactive power direction recorded at the grid connection point is opposite to the inverter's reactive power direction.

**step 5** Click **Save**.

-- End

### 13.6.2 Locally Regulating Reactive Power

Configure the parameters for local reactive power control.

#### Prerequisites

- The **Reactive Control Mode** is currently set to **Local Power Control**. Refer to [13.4 Selecting Power Control Mode](#).
- For closed-loop control, a gateway meter for power control must be connected.

**step 1** In the drop-down list **Control Method**, select **Open-loop Control** or **Closed-loop Control**.

**step 2** In the drop-down list **Instruction Type**, select the designated unit for power regulation.

- **PF:** Adjusts power based on the power factor. Recommended for scenarios where the inverter needs to maintain a specific power factor level.
- **%:** Adjusts power based on a percentage of the inverter's maximum rated power. Recommended for scenarios where the output needs to be adjusted according to the inverter's capacity.

**step 3** When **Open-loop Control** is selected, refer to the local active power control and configure the corresponding parameters. Refer to [13.5.2.1 Open-Loop Control](#).

**step 4** When **Closed-loop Control** is selected, refer to the local active power control and configure the corresponding parameters. Refer to [13.5.2.2 Closed-Loop Control](#).

**step 5** When **Closed-loop Control** is selected, in the field **Line Reactive Power Compensation**, estimate and set the reactive power loss in the line.

**step 6** Refer to local active power control and add dispatch time and target values. Refer to [13.5.2.3 Configuring Adjustment Time and Target Values](#).

-- End

### 13.6.3 Regulating Reactive Power via Analog Input

#### Prerequisites

- The **Reactive Control Mode** is currently set to **Analog Input**. Refer to [13.4 Selecting Power Control Mode](#).
- For closed-loop control, a gateway meter for power control must be connected.

**step 1** In the drop-down list **Control Method**, select **Open-loop Control** or **Closed-loop Control**.

**step 2** When **Closed-loop Control** is selected, configure the following parameters.

- i. In the drop-down list **Select energy meter/transformer**, select the meter or transformer for power regulation.
- ii. In the drop-down list **Control Cycle**, specify the interval at which the Logger1000 sends dispatch commands to the inverter.

**step 3** In the drop-down list **AI Port**, select the AI port that accepts the analog input signals.

To configure the AI port parameters, click **AI Configuration** to navigate to the **System > Port Parameter > AI** page. See [8.5 Analog Input \(AI\) Port](#).

**step 4** In the drop-down list **Instruction Type**, select the designated unit for power regulation.

- **PF**: Adjusts power based on the power factor. Recommended for scenarios where the inverter needs to maintain a specific power factor level.
- **%**: Adjusts power based on a percentage of the inverter's maximum rated power. Recommended for scenarios where the output needs to be adjusted according to the inverter's capacity.

**step 5** Depending on the **Instruction Type**, in the field **Min** and **Max**, set the target value range for power control.

- **%** : The range of **Min** and **Max** is -100% to 100%.
- **PF** : The range of **Min** and **Max** is -1~-0.8 or 0.8 to 1.



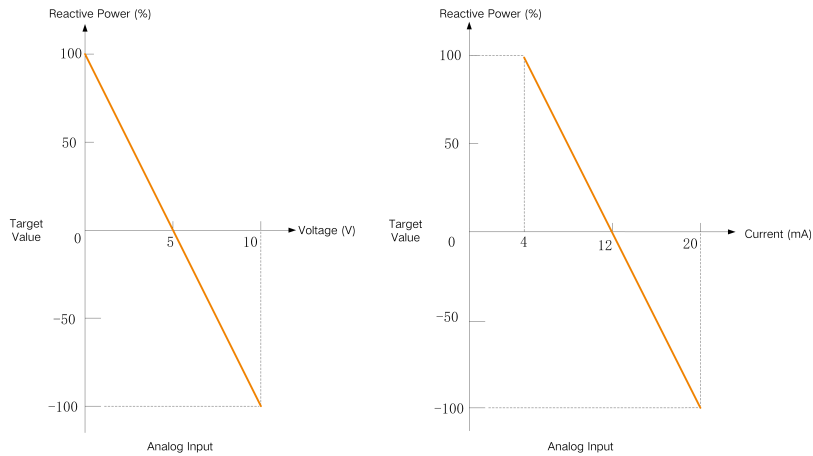

**figure 13-10** Example of the relationship between analog input values and target values

**step 6** Depending on **Instruction Type**, in the field **Step**, set the minimum difference value between two consecutive power control commands.

**step 7** For with **Instruction Type** to **PF**, in the field **Hysteresis Range**, specify a deadband range that maintains the PF at  $\pm 1$  to avoid frequent sudden changes in power factor.

**step 8** Click **Save**.

-- End

### 13.6.4 Regulating Reactive Power via Digital Input

#### Prerequisites

- The **Reactive Control Mode** is currently set to **Digital Input**. Refer to [13.4 Selecting Power Control Mode](#).
- For closed-loop control, a gateway meter for power control must be connected.

**step 1** In the drop-down list **Control Method**, select **Open-loop Control** or **Closed-loop Control**.

**step 2** When **Closed-loop Control** is selected, configure the following parameters.

- In the drop-down list **Select energy meter/transformer**, select the meter or transformer for power regulation.
- In the drop-down list **Control Cycle**, specify the interval at which the Logger1000 sends dispatch commands to the inverter.

**step 3** In the drop-down list **Instruction Type**, select the designated unit for power regulation.

- **PF**: Adjusts power based on the power factor. Recommended for scenarios where the inverter needs to maintain a specific power factor level.
- **%**: Adjusts power based on a percentage of the inverter's maximum rated power. Recommended for scenarios where the output needs to be adjusted according to the inverter's capacity.

**step 4** In the table at the bottom of the page, set the target values for power control corresponding to the digital input signals.

- i. Based on the dry contact signals received by the DI ports, check the corresponding DI port.
- ii. Depending on the **Instruction Type**, enter a percentage or a power factor for reactive power control.



To delete the DI signal configuration, select the checkbox in the first column of the row, and click **Clear Data** .

**step 5** Click **Save**.

-- End

### 13.6.5 Regulating Reactive Power via Country Mode

Implements power regulations according to the commands issued by the national grid dispatching center.

#### Prerequisites

- The **Reactive Control Mode** is currently set to **Country Mode**. See [13.4 Selecting Power Control Mode](#).

**step 1** In the drop-down list **Country**, select the country where inverters are located.

**step 2** When the country is set to **Korea**, configure the following parameters.

- i. In the drop-down list **PPC Type**, select the power plant controller DER-AVM.
- ii. In the field **Forwarding Modbus ID**, enter the Modbus forwarding address (Range: 1~10).
- iii. In the drop-down list **Instruction Type**, select the type of dispatch commands.

**step 3** Click **Save**.

-- End

### 13.6.6 Disabling Reactive Power Control

Disable the Logger1000 from controlling reactive power to the inverter.

**step 1** On the **Reactive Power** page, set **Reactive Control Mode** to **Disable Dispatching**.

**step 2** Click **Save**.

- - End

Once the settings are completed, the inverter will continue to operate with the current reactive power adjustment limit.

### 13.6.7 Disabling Reactive Power Output

In certain situations, such as when the grid company does not require voltage regulation at the grid-connection point and no reactive power compensation is needed, you can set the inverter to stop reactive power output. This helps maintain overall grid stability and prevents voltage fluctuations caused by reactive power adjustment.

**step 1** On the **Reactive Power** page, set **Reactive Control Mode** to **Disable Output**.

**step 2** Click **Save**.

- - End

Once the settings are completed, the inverter's reactive power output will return to "0%".

## 13.7 Setting Emergency Stop

If the emergency stop switch is activated, the Logger1000 will initiate a batch power-off operation on the inverters.

#### Prerequisites

- The Logger1000 is connected to the emergency stop device.

**step 1** Click **Power Control > Emergency Button** to navigate to the corresponding page.

**step 2** Set **Emergency Button** to **Enable**.

**step 3** Optional: Set Inverter Status During Emergency Stop Recovery to **Boot**.

After resetting the emergency stop switch, the inverters will automatically power on.

**step 4** Click **Save** to apply the changes.

- - End



If the inverters remain in standby mode after resetting the emergency stop switch, manually start the inverters through **Device Monitoring > Device Instruction** . If there is any problem, contact SUNGROW.

## 13.8 Configuring Cascaded Scheduling



Cascaded Scheduling is available on LOGGER-SV300.001.00.P044 or later.

**step 1** Navigate to **Device Maintenance > Device List**.

**step 2** Click **Add Device** and set **Device Type** to SUNGROW Logger in the pop-up window.

**step 3** Select the status of host-client scheduling control in **Cascaded Scheduling**.

- **Enable:** Enable Cascaded Scheduling, where the client Logger1000 is subject to the control by the host Logger1000. Multiple Logger1000 devices are cascaded and the current Logger1000 serves as the host.



In Cascaded Scheduling mode, to use a client Logger1000 device for energy management or power regulation, first log in to the host Logger1000 in the system and disable Cascaded Scheduling for that client.

- **Disable:** Disable Cascaded Scheduling, where the client Logger1000 is not controlled by the host Logger1000. All inverters are connected to the same Logger1000 device and the inverters must all be string inverters or central inverters.

-- End

# 14 Power Control (Energy Storage System)



In the energy management scenario, the options for power control may vary depending on the firmware version of the Logger1000. Always refer to the actual interface for up-to-date and precise information.

## 14.1 Settings for Active Power Control

### Prerequisites

- The web UI has switched to the energy management scenario.

### 14.1.1 Power Regulation using Digital Inputs

The DI power control support Demand Response Management (DRM) and Ripple Control systems through dry contact communication. If an emergency stop device is connected, an emergency stop function can be implemented for additional safety and control.

The following options are supported:

- **DRM**
- **Ripple Control**



To disable power control using DI, in the drop-down list **DI Control Method** , select **Close** .

#### 14.1.1.1 Controlling Power via DRM

Demand Response Management (DRM) is a method for controlling power consumption that adjusts the load in response to signals from the power grid.

**step 1** Click **Power Control > Active Power** to navigate to the corresponding page.

The **DI Power Regulation** tab page displays.

**step 2** In the drop-down list **DI Control Method**, select **DRM**.

**step 3** Click **Save**.

-- End

#### 14.1.1.2 Controlling Power via Ripple Control

The Ripple Control mode adjusts power according to the grid's control signal received through dry contacts, suitable for Germany and other parts of Europe.

When Ripple Control is activated, dispatch signals are conveyed by the power grid company through digital input ports. There are 16 available DI signal configurations, each associated

with a specific power ratio. You must configure these DI ports on the Web UI according to the requirements of the utility company to correctly receive and respond to these signals.

**table 14-1** Signal states of DI ports

Icon	Description
<input type="checkbox"/>	The digital signal source is in an open state.
<input checked="" type="checkbox"/>	The digital signal source is in a closed state.



Each DI signal configuration must be unique.

**step 1** Click **Power Control > Active Power** to navigate to the corresponding page.

The **DI Power Regulation** tab page displays.

**step 2** In the drop-down list **DI Control Method**, select **Ripple Control**.

**step 3** In the drop-down list **Inverter Output Power Limit Ratio Calculation Basis**, select the reference for limiting the inverter's output power.

- **Nominal Power:** Calculate the value to be sent for power control based on the inverter's rated power.
- **Installed PV Power:** Calculate the value to be sent for power control based on the installed PV capacity. Enter the total installed power of PV modules at the power plant.

**step 4** Check the digital signal ports and specify the desired power ratio (range: 0-100%).

A default DI signal configuration appears below for initial setup.

**step 5** Click  to add additional DI signal configurations.

**step 6** Click **Save**.

-- End

### 14.1.1.3 Setting Emergency Stop

When the emergency stop function is enabled, you can initiate an emergency shutdown of the inverter.

#### Emergency stop modes

Mode	Description
<b>Close</b>	Do not enable the emergency stop.
<b>Stop Inverter</b>	When the emergency stop is activated, the inverters will cease feeding electricity into the grid and will not accept electricity from the grid. The inverter enters emergency stop state.

Mode	Description
<b>Stop Inverter and Trip Battery</b>	When the emergency stop is, the inverters will cease feeding electricity into the grid, and the batteries will also stop electrical interaction with the inverters and the grid. This means the batteries will neither charge nor discharge. The inverter enters emergency stop state, and the battery enters a tripped state.

#### Prerequisites

- The Logger1000 is connected to the emergency stop device.

**step 1** Click **Power Control > Active Power** to navigate to the corresponding page.

The **DI Power Regulation** tab page displays.

**step 2** In the drop-down list **Emergency Stop Function**, select whether to enable the emergency stop function and the preferred emergency stop mode.



If the batteries enter standby mode due to an emergency stop, they need to be manually restarted to resume normal operation.

**step 3** If **Stop Inverter** or **Stop Inverter and Trip Battery** is selected, in the drop-down list **Emergency Stop Status**, specify which state of the digital signal source from the DI5 port will initiate the emergency stop.

- **Disconnect:** The emergency stop is triggered when the emergency stop switch is in an open state.
- **Closed:** The emergency stop is triggered when the emergency stop switch is in a closed state.

**step 4** Click **Save**.

-- End

### 14.1.2 Local Power Control

If active power is controlled locally, the system directly accepts adjustment commands from the Logger1000. You can configure feed-in power related parameters to prevent anti-backflow or achieve zero power feed-in. When a communication failure occurs between the

Logger1000 and the meter, you can configure the relevant parameters to effectively manage and maintain the inverter's power output.



You can set feed-in power limit parameters on the page **Power Control > Grid-connection Power Regulation** or **Power Control > Active Power** . In practical applications, if settings are made in two places simultaneously, the smaller value will prevail.

### Prerequisites

- For closed-loop control, a gateway meter for power control must be connected.

**step 1** Click **Power Control > Active Power** to navigate to the corresponding page.

The **DI Power Regulation** tab page displays.

**step 2** Select tab **Local Power Control**.

**step 3** In the drop-down list **Local Power Control Method**, select **Closed-loop Control**.

**step 4** When the communication with the meter is interrupted, configure the relevant parameters of the Logger1000.

- i. In the field **Power Limit in Case of Meter Communication Anomaly**, specify the target value as a percentage to be issued by the Logger1000 when there is a communication failure with the meter.

When **Power Limit in Case of Meter Communication Anomaly** is set to "0%", the Logger1000 will send a shutdown command to the inverter after confirming the communication failure with the meter.

- ii. When the inverters are shut, in the drop-down list **Start After Communication Recovery**, select whether the Logger1000 should send a power-on command to the inverters when communication with the meter resumes.

- **Enable**: When the communication resumes, the inverter will restart.
- **Disable**: When the communication resumes, the inverter will remain shut down.

- iii. In the field **Start Delay After Communication Recovery**, specify the waiting time for the Logger1000 to send a power-on command to the inverter after communication is restored.



**step 5** In the drop-down list **Feed-in Stop**, select whether the Logger1000 should send a shutdown command to the inverter when grid power feed-in is detected.

- **Enable:** The inverter will shut down when feed-in power is detected by the meter. Select this option when zero power feed-in is required.



After the inverter shuts down, if the meter detects that the power draw exceeds 10% of the system's rated power, the Logger1000 will send a power-on command to the inverter.

- **Disable:** The inverter will remain on even when feed-in power is detected by the meter.

**step 6** In the drop-down list **Feed-in Control Mode**, select the grid control mode according to the type of data the meter collects.

- **Total Active Power Control:** The meter collects three-phase data on the grid side as the feedback value for regulation.
- **Split Phase Active Power Control:** The meter collects single-phase data as the feedback value for regulation.

**step 7** In the field **Over-scaling**, enter the desired value for over-scaling.

Based on the initial power limit target, Logger1000 will adjust the inverter's output once to ensure it stays below the set limit, without the need for repeated adjustments. It is recommended to use this parameter in scenarios that require stringent power control, such as anti-backflow or achieving zero power feed-in.

**step 8** Specify the unit for the target value: **kW** or **%**.

**step 9** When the unit for target value is set to **kW**, set a reasonable feed-in power value according to local regulations.

**step 10** When the unit for target value is set to **%**, in the drop-down list **Feed-in Power Limit Ratio Calculation Basis**, select a reference for limiting the grid-connected power.

- **Nominal Power:** Calculate the value to be sent for power control based on the inverter's rated power.
- **Installed PV Power:** Calculate the value to be sent for power control based on the installed PV capacity. Enter the total installed power of PV modules at the power plant.

**step 11** Click **Save**.

-- End

### 14.1.3 Remote Power Control

When controlling active power remotely, the system receives adjustment commands through TCP services such as Modbus TCP.



Using remote control to adjust active power automatically deactivates any locally selected energy management modes. Adjustments are made through commands from the remote backend.

**step 1** Click **Power Control > Active Power** to navigate to the corresponding page.

The **DI Power Regulation** tab page displays.

**step 2** Select tab **Remote Power Control**.

**step 3** In the drop-down list **Remote Power Control Method**, select **Open-loop Control**.

**step 4** Click **Save**.

- - End

## 14.2 Settings for Reactive Power Control

If reactive power is controlled locally, the system directly accepts adjustment commands from the Logger1000. You can configure the power factor for the grid-connection point. Once configured, the inverter adjusts its reactive output based on the meter's data to maintain grid stability and efficiency.

### Prerequisites

- The web UI has switched to the energy management scenario.

**step 1** Click **Power Control > Reactive Power** to navigate to the corresponding page.

The **Local Power Control** tab page displays.

**step 2** In the drop-down list **Local Power Control Method**, select **Closed-loop Control**.

**step 3** In the drop-down list **Instruction Type**, select the designated unit for power regulation. The default is **PF** (power factor).

**step 4** In the field **Line Reactive Power Compensation**, estimate and set the reactive power loss in the line.

**step 5** In the drop-down list **Control Cycle**, specify the interval at which the Logger1000 sends dispatch commands to the inverter.

**step 6** In the field **Target Power Factor**, enter the target power factor for adjustment based on the actual energy usage at the power station. Data range: -1 to -0.8 or 0.8 to 1.

**step 7** Click **Save**.

- - End

## 14.3 Configuring Cascaded Scheduling



Cascaded Scheduling is available on LOGGER-SV300.001.00.P044 or later.

**step 1** Navigate to **Device Maintenance > Device List**.

**step 2** Click **Add Device** and set **Device Type** to SUNGROW Logger in the pop-up window.

**step 3** Select the status of host-client scheduling control in **Cascaded Scheduling**.

- **Enable:** Enable Cascaded Scheduling, where the client Logger1000 is subject to the control by the host Logger1000. Multiple Logger1000 devices are cascaded and the current Logger1000 serves as the host.



In Cascaded Scheduling mode, to use a client Logger1000 device for energy management or power regulation, first log in to the host Logger1000 in the system and disable Cascaded Scheduling for that client.

- **Disable:** Disable Cascaded Scheduling, where the client Logger1000 is not controlled by the host Logger1000. All inverters are connected to the same Logger1000 device and the inverters must all be string inverters or central inverters.

-- End

# 15 Energy Management

In the energy management scenario, you can control the energy distribution of the energy storage system by limiting grid-connected power, selecting a working mode, and adjusting active or reactive power.

## 15.1 Requirements

### 15.1.1 Adding a Meter

#### Prerequisites

- The web UI has switched to the energy management scenario.
- The meter is connected to the Logger1000.

**step 1** Navigate to the page **Device > Device List**, and click **Add Device** to open the **Add Device** dialog box.

**step 2** In the drop-down list **Device Type**, select **Meter**.

**step 3** Select the type of the meter.

- In the drop-down list **Access Type**, select the type of the meter according to its purpose and actual installation location: **Electricity Meter** or **Gateway Meter**.

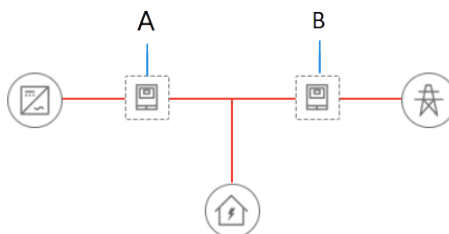

Position	Type	Description
A	Electricity meter	Used to monitor power consumption on the inverter side.
B	Gateway meter	Used to monitor power consumption on the grid side.

- ii. If **Electricity Meter** is selected, in the drop-down list **Meter Usage**, select the purpose of the meter based on the actual use scenario.
  - **Fcas Sampling**:: This meter is used for grid-data sampling for Frequency Control Ancillary Services (FCAS). Select this option for scenarios involving integration with the FCAS system in Australia. After configuration, the FCAS system regulates the inverter's power generation to maintain the stability of the energy storage system.
  - **Third-party Power System Sampling**: This meter is used for monitoring energy consumption and production in third-party generation systems. Recommended for scenarios that involve connecting to third-party inverters.
- iii. If **Gateway Meter** is selected, in the drop-down list **Meter Usage**, select the purpose of the meter based on the actual use scenario.
  - **Grid-connected Power Control**:: This meter is used for monitoring and controlling the power station's output power. By default, the system regulates power based on the feedback values recorded by the meter.
  - **Grid-connected Power Monitoring**:: This meter is used for collecting data from associated devices and syncs it to the cloud. Recommended for verifying data at the grid-connection point.

**step 4** In the drop-down list **Port**, select the port that the meter is connected to.

**step 5** If **NET** is selected, set the network parameters for the meter.

- i. In the drop-down list **Protocol Type**, select the communication method between the meter and the Logger1000. The default is **MODBUS-TCP**.
- ii. In the fields **Peer IP Address** and **Peer Port**, enter the IP address and port number of the meter, respectively.

**step 6** In the drop-down list **Device Model**, select the model of the meter.



If the model is not in the drop-down list, select **Others**, and import the meter information either by setting measuring points or by uploading a configuration file.

**step 7** Enter the address of the meter based on the selected model.

**step 8** Click **Save**.

**step 9** If you need to change the type of the meter, the page modify its initial parameters on the page **Device Monitoring**.

-- End

### 15.1.2 Controlling Grid-Connection Power

You need to set the power thresholds for the energy storage system first. The power thresholds for drawing and feeding set the maximum power of the system during grid

connection, ensuring system stability and energy efficiency. These thresholds will affect the actual range of power control.

### Prerequisites

- The web UI has switched to the energy management scenario.



You can set feed-in power limit parameters on the page **Power Control > Grid-connection Power Regulation** or **Power Control > Active Power** . In practical applications, if settings are made in two places simultaneously, the smaller value will prevail.

**step 1** Click **Power Control > Grid-connection Power Regulation** to navigate to the corresponding page.

**step 2** In the drop-down list **Energy Purchase Control Method**, select **No Limit** or **Purchase Energy with Limited Power**.

**step 3** If **Purchase Energy with Limited Power** is selected, in the field **Power Limit for Energy Purchase**, specify a value based on the rated current of the primary power source equipment connected to your system, such as the household's main circuit breaker.

**step 4** In the drop-down list **Feed-in Control Method**, select **No Limit** or **Feed-in Limited Power**.

**step 5** If **Feed-in Limited Power** is selected, specify the unit for the target value: **kW** or **%**.

**step 6** When the unit for target value is set to **kW**, set a reasonable feed-in power value according to local regulations.

**step 7** When the unit for target value is set to **%**, in the drop-down list **Feed-in Power Limit Ratio Calculation Basis**, select a reference for limiting the grid-connected power.

- **Nominal Power**: Calculate the value to be sent for power control based on the inverter's rated power.
- **Installed PV Power**: Calculate the value to be sent for power control based on the installed PV capacity. Enter the total installed power of PV modules at the power plant.

**step 8** In the drop-down list **Swift grid dispatching mode**, select whether to enable rapid grid dispatching.

To meet strict zero power feed-in or anti-backflow requirements, it is recommended to enable this mode for faster active power control.

**step 9** **Disable** or **Enable** the **Third-Party Power Generation Systems**

Users can make selection based on their actual needs if any third-party inverter is connected in the system.



This step is applicable to LOGGER-SV300.001.00.P044 or later.

**step 10** If **Enable** is selected in **Third-Party Power Generation Systems**, users can specify the rated power in **Rated Power of Third-Party Power Generation Systems (kW)**. Range: 0–99999999, unit: kW. The default value is 0

Users can specify the Rated Power of Third-Party Power Generation Systems based on the rated power of the connected third-party inverter.



This step is applicable to LOGGER-SV300.001.00.P044 or later.

**step 11** Click **Save**.

-- End

## 15.2 Selecting Energy Management Working Modes

You can select a desired working mode to effectively manage electricity.



Before selecting a working mode for energy management, make sure to disable remote power control on the Logger1000.

The following working modes are supported for the Logger1000:

Mode	Description
<b>Self-Consumption</b>	Suitable for scenarios where photovoltaic power generation fully meets load requirements. This mode maximizes the use of the photovoltaic system and battery storage for power supply, achieving energy self-sufficiency through demand control and battery usage plans.
<b>Time Plan</b>	Suitable for scenarios with significant differences in peak and off-peak electricity prices. This mode optimizes energy costs by scheduling specific battery charging and discharging times.
<b>VPP</b>	A Virtual Power Plant (VPP) is an energy management system that integrates multiple distributed energy resources into a centralized, virtual power generation and management system. Suitable for scenarios that require energy management through external systems.
<b>Compulsory Mode</b>	Suitable for scenarios where the energy storage system needs to respond immediately to charging and discharging commands. Recommended for the system installation and commissioning phase.

### 15.2.1 Self-Consumption

The self-consumption mode is designed to maximize the use of photovoltaic (PV) generation and battery-stored energy to supply power to loads, thereby reducing electricity drawn from the grid. Additionally, you can set desired battery charging and discharging times based on varying electricity prices to reduce costs.

#### Energy supply and energy consumption precedence

When PV generation is sufficient, the system prioritizes using solar power to meet load demands, storing excess energy in the batteries. If there is still surplus PV energy, the system feeds the excess back to the grid.

When PV generation cannot meet load demands, the system utilizes stored battery power. If both PV output and battery storage are insufficient, the system draws additional power from the grid.

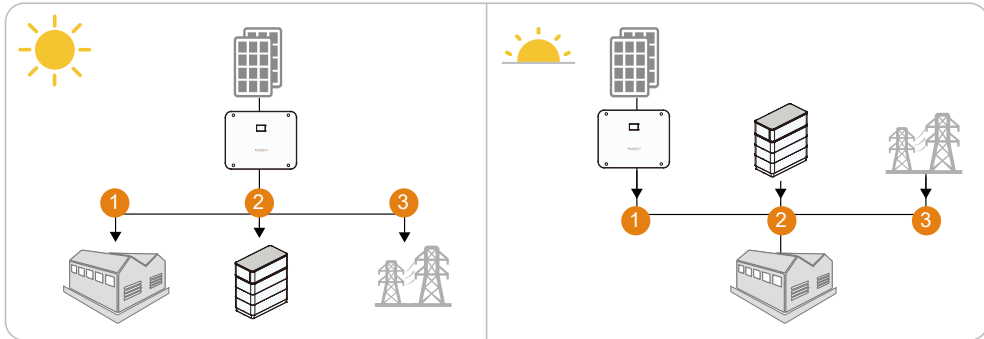

#### Example

Assuming the PV installation power of the inverter is 10kW, with the inverter's rated power at 5kW, and the maximum charge and discharge power of the battery also at 5kW, the system operates as follows.

When there is sufficient sunlight:

- If the PV generates 7kW and the load demands 3kW, then the surplus of 4kW will be used to charge the batteries.
- If the PV generates 10kW and the load demands 3kW, then the batteries will charge at its maximum capacity of 5kW, and the remaining 2kW will be fed into the grid.



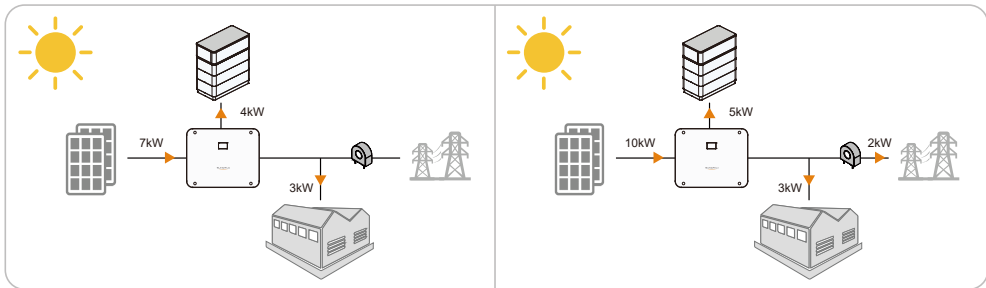

When there is insufficient sunlight:

- If the PV generates 2kW and the load demands 4kW, then the batteries will supply 2kW to meet the load requirements.
- If the PV generates 2kW and the load demands 7kW, then the batteries will discharge at 3kW, and the system will pull an additional 2kW from the grid.

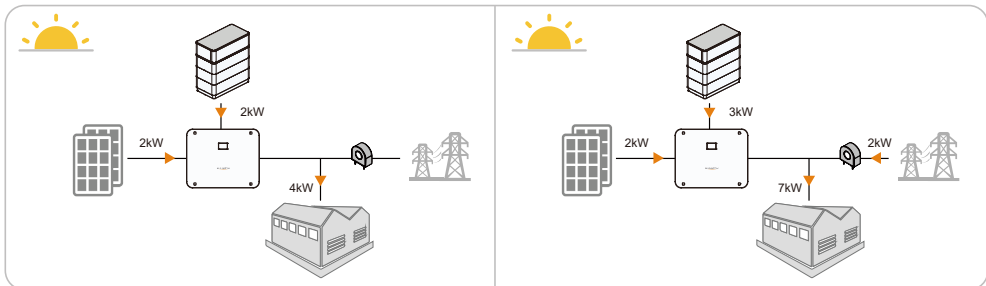

### Prerequisites

- The web UI has switched to the energy management scenario.

**step 1** Click **Energy Management** to navigate to the corresponding page.

**step 2** In the drop-down list **Working Mode**, select **Self-Consumption**.

**step 3** Click **Save**.

-- End

#### 15.2.1.1 Demand Control

Demand control refers to setting the power thresholds for drawing from and feeding into the grid by the storage system. In the self-consumption mode, you can adjust power supply and consumption precedence based on different sunlight conditions to either reduce electricity costs or increase feed-in profits. You can set power thresholds according to real situations.

#### Threshold on Power Feed-in (Demand Control)

Setting the feed-in threshold means setting the power level for feeding electricity back into the grid. When sunlight is sufficient to meet load demands, you can gain economic

benefits from feeding surplus electricity into the grid. If there is an abundance of sunlight, it is recommended to configure **Threshold on Power Feed-in (Demand Control)**, so that excess solar energy is fed into the grid first, changing the precedence in which the energy storage system supplies electricity.

After configuration, when there is enough sunlight, the energy storage system first meets the load demands, and then feeds any extra solar electricity into the grid. Only when the **Threshold on Power Feed-in (Demand Control)** exceeds a certain threshold will the excess be used to charge the battery.

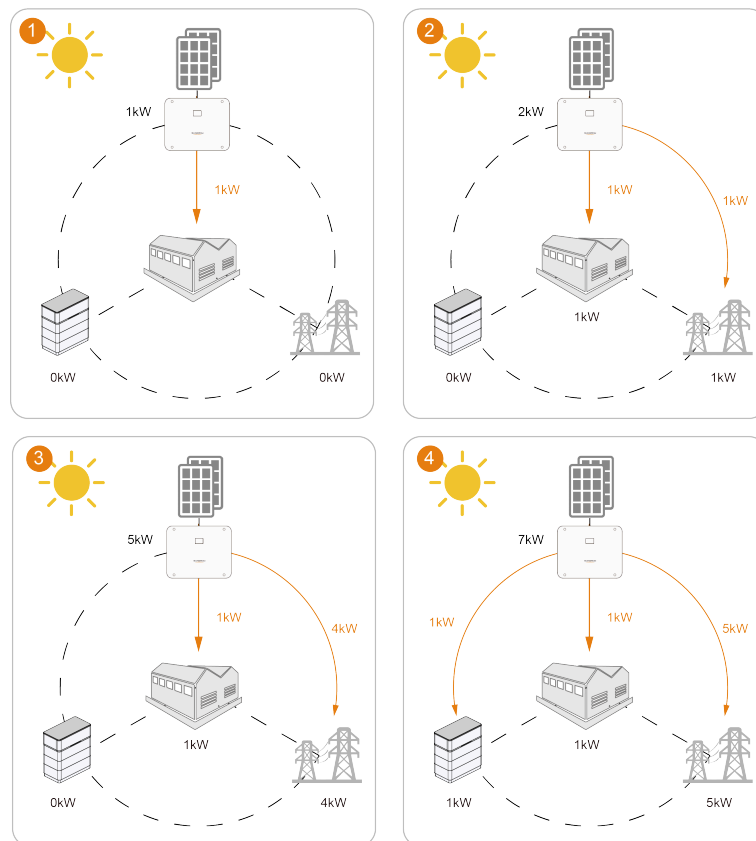

**figure 15-1 Power supply precedence (when **Threshold on Power Feed-in (Demand Control)** is set to 5kW)**

### **Threshold on Power Purchase (Demand Control)**

Setting the power purchase threshold means setting the power level for the load to draw electricity from the grid. In some regions, to encourage users to reduce electricity use during peak times and decrease the load on the grid, utility companies charge extra fees based on the peak electricity use within a certain time frame. In such cases, it is recommended to

configure **Threshold on Power Purchase (Demand Control)** to change the precedence in which the energy storage system draws power.

After configuration, when sunlight is insufficient and the solar power output is not enough for the load, the storage system controls the load to prioritize drawing power from the grid. When the draw power exceeds the set threshold, the system switches to drawing from the battery, thereby reducing electricity costs.

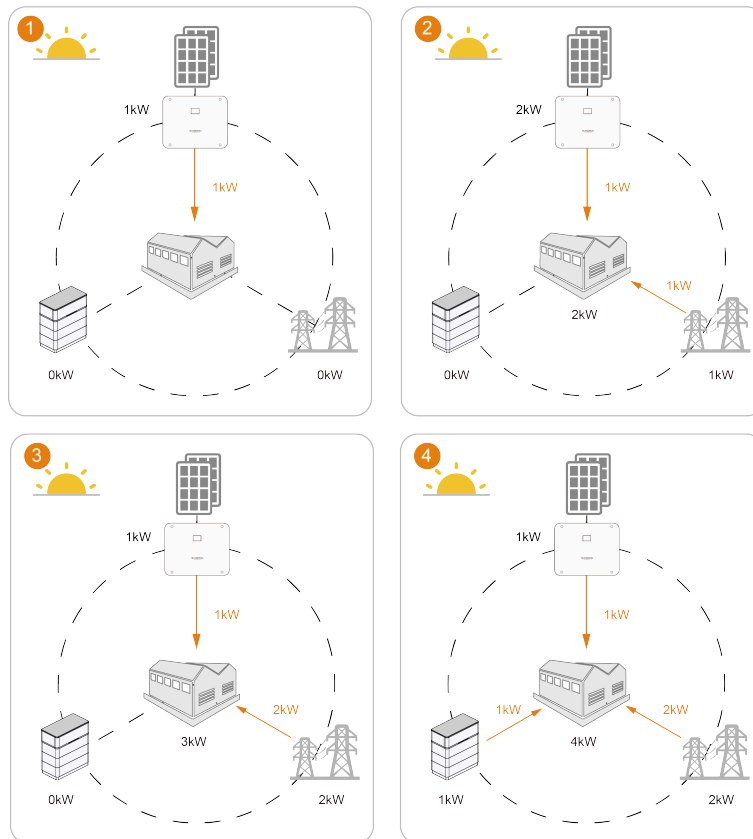

**figure 15-2** Power consumption precedence (when **Threshold on Power Purchase (Demand Control)** is set to 2kW)

### Prerequisites

- The working mode for energy management has selected **Self-Consumption**. See [15.2.1 Self-Consumption](#).

**step 1** In the field **Threshold on Power Purchase (Demand Control)**, enter the maximum allowed value for power consumption from the grid (Default value: 0).

**step 2** In the field **Threshold on Power Feed-in (Demand Control)**, enter the maximum allowed grid feed-in power value (Default value: 0).

**step 3** Click **Save**.

- - End

### 15.2.1.2 Adding Battery Usage Plan

In the self-consumption mode, you can customize battery charging and discharging time slots to ensure the system maximally utilizes PV generation during peak demand periods and minimizes grid electricity usage during low PV generation periods.

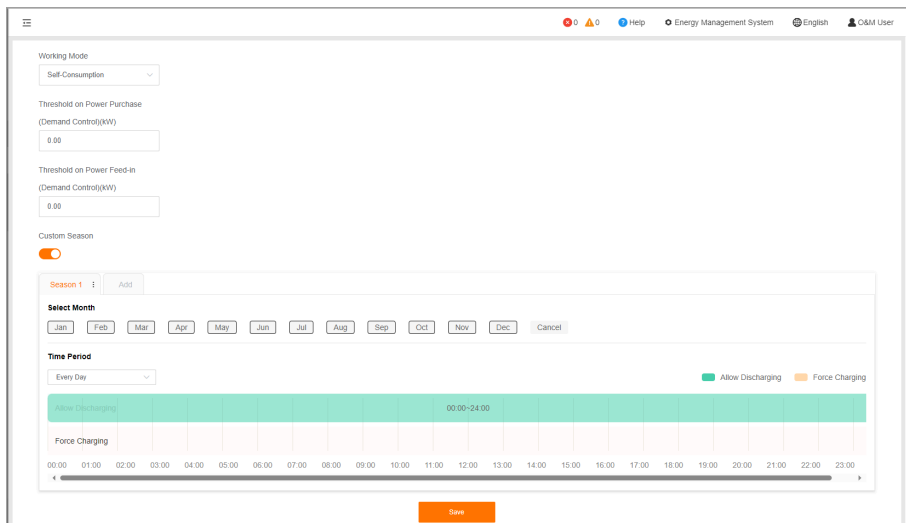

Battery usage times and forced charging times may overlap. In such scenarios, forced charging takes precedence.



It is recommended to set the period of high electricity prices as **Allow Discharging**, and the period of low electricity prices as **Force Charging**.

#### Discharging time

When adding time slots in timeline **Allow Discharging**, in the specified time period, the battery is allowed to discharge and power your loads. The default setting allows for battery discharge continuously throughout the day (0-24h).

### Forced charging time



When adding time slots in timeline **Force Charging**, in the specified time period, the battery will charge at its maximum allowable power within the specified period until it reaches the desired State of Charge (SOC). This process is not restricted by **Threshold on Power Feed-in (Demand Control)**. If PV generation is insufficient, the system will draw from the grid to complete charging. There is no default time set for forced charging.

- When PV generation is sufficient, the system first uses PV generation to charge the battery. Excess energy is supplied to the loads. If there is still surplus PV energy, the system feeds the excess back to the grid.
- When PV generation is insufficient, the system prioritizes battery charging. If solar power generation cannot meet the battery's needs, the system will purchase electricity from the grid. The loads also draw power from the grid.

### Time periods without specific settings

The battery cannot discharge, and it is not allowed to draw power from the grid for charging. The battery can only be charged by solar power.

- The primary goal is to use as much of the energy generated by the PV system as possible for current energy needs (loads). Any additional energy produced is stored in batteries for future or nighttime use. If PV energy exceeds the total demand of both the battery and the loads, the additional power is fed back to the grid.
- However, when solar power is not enough to meet load demands, the battery does not discharge, and the system buys power from the grid to meet the load requirements.

Status of time slots	Description
	When there is a time indicator on the slot, it means that discharging or charging times have been set within that time range.
	<p>The time slot will be highlighted and selected when you hover your mouse over it. You can perform the following:</p> <ul style="list-style-type: none"> <li>• Click and drag the boundary of a time slot to modify its start and end time. The minimum time range for a time slot is 15 minutes.</li> <li>• Click the upper-right corner of the time slot to delete it.</li> </ul>

### Prerequisites

- The working mode for energy management has selected **Self-Consumption**. See [15.2.1 Self-Consumption](#).

#### step 1 Turn on the switch **Custom Season**.

By default, one seasonal schedule is displayed and all 12 months are selected.

**step 2** Under the field **Select Month**, select the applicable months for the current settings.

You can customize time slots according to the energy demand patterns and seasonal variations of each month.



**step 3** In the drop-down list **Time Period**, select the scheduling pattern for battery charging and discharging.

The charging and discharging schedule can be configured to activate daily or to specifically target weekdays or weekends. By default, the schedule is set to activate daily.

- **Every Day**(Default): The charging and discharging time slots are applied to each day. It is recommended for locations where energy needs do not vary significantly from day to day.
- **Weekdays&Weekends**: Set distinct charging and discharging time slots for typical workdays or weekends, accommodating different energy usage patterns.

**step 4** If **Every Day** is selected, directly set the battery discharging and enforced charging times.

- On the timeline **Allow Discharging**, click on the desired start point to add a discharge time slot. The default duration for a time slot is one hour.
- On the timeline **Force Charging**, click on the desired start point to add an enforced charging time slot. The default duration for a time slot is one hour.
- Click on the time slot to open the floating window. In the field **Target SOC**, specify the desired target SOC percentage for the enforced charging session.

**step 5** If **Weekdays&Weekends** is selected, click   , to configure battery discharging and forced charging times for weekdays and weekend scenarios separately.

**step 6** To add a seasonal schedule, click **Add** next to the default seasonal schedule.



On the seasonal schedule tab, click  to edit the name of the schedule, or delete it.

**step 7** Click **Save**.

-- End

### Example

Assuming the PV installation power of the inverter is 10kW, with the inverter's rated power at 5kW, and the maximum charge and discharge power of the battery also at 5kW, the system operates as follows.

When setting the time from 14:00 to 24:00 as the time slot for **Allow Discharging**, and 0:00 to 8:00 as the time slot for **Force Charging**, with **Target SOC** set to "100%", the power distribution is as follows:

- 0:00 to 8:00: When the battery's state of charge is below **Target SOC**, it draws power from the grid to charge the battery until the SOC requirements are met and then stops.
- 8:00 to 14:00: no settings are configured for this time period. When solar power generation cannot meet the load demands, the battery is not allowed to discharge,

and the system will directly purchase power from the grid. If the battery's energy is insufficient, the system only uses solar power to charge the battery.

- 14:00 to 24:00: When solar power is insufficient to meet the load demands, the system controls the battery to discharge.

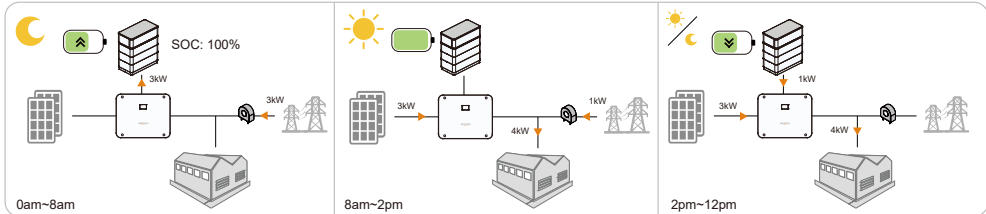

### 15.2.2 Time Plan

The time plan mode mainly used in energy trading scenarios, leveraging differences between peak and off-peak pricing to manually set times and powers for battery charging and discharging to maximize economic benefits.



According to the TOU electricity prices, it is recommended to set the peak hours as **Discharge** , and the off-peak hours as **Charge** .

#### Discharging time

When adding time slots in the timeline **Discharge**, in the specified time period, the battery will discharge at the set power level until it is fully discharged.

#### Charging time

When adding time slots in the timeline **Charge**, in the specified time period, the battery will charge at the set power level until it is fully charged.

- When PV generation is sufficient, the system first uses PV generation to charge the battery. Excess energy is supplied to the loads. If there is still surplus PV energy, the system feeds the excess back to the grid.
- When PV generation is insufficient, the system prioritizes battery charging. If solar power generation cannot meet the battery's needs, the system will purchase electricity from the grid. The loads also draw power from the grid.



The discharging time and charging time must not overlap.

#### Time periods without specific settings

The battery cannot discharge, and it is not allowed to draw power from the grid for charging. The battery can only be charged by solar power.

- The primary goal is to use as much of the energy generated by the PV system as possible for current energy needs (loads). Any additional energy produced is stored in batteries for future or nighttime use. If PV energy exceeds the total demand of both the battery and the loads, the additional power is fed back to the grid.
- However, when solar power is not enough to meet load demands, the battery does not discharge, and the system buys power from the grid to meet the load requirements.

### 15.2.2.1 Selecting the Time Plan Mode

#### Prerequisites

- The web UI has switched to the energy management scenario.

**step 1** Click **Energy Management** to navigate to the corresponding page.

**step 2** In the drop-down list **Working Mode**, select **Time Plan**.

**step 3** Click **Save**.

-- End

### 15.2.2.2 Configuring Battery Usage Plan

#### Prerequisites

- The working mode for energy management has selected **Time Plan**. See [Time Plan](#).

**step 1** Click **Energy Management** to navigate to the corresponding page.

**step 2** In the drop-down list **Working Mode**, select **Time Plan**.

**step 3** Under the field **Select Month**, select the applicable months for the current settings.

You can customize time slots according to the energy demand patterns and seasonal variations of each month.

**step 4** In the drop-down list **Time Period**, select the scheduling pattern for battery charging and discharging.

The charging and discharging schedule can be configured to activate daily or to specifically target weekdays or weekends. By default, the schedule is set to activate daily.

- **Every Day**(Default): The charging and discharging time slots are applied to each day. It is recommended for locations where energy needs do not vary significantly from day to day.
- **Weekdays&Weekends**: Set distinct charging and discharging time slots for typical workdays or weekends, accommodating different energy usage patterns.

**step 5** If **Every Day** is selected, directly set the time slots for battery discharging and enforced charging.

- i. On the timeline **Discharge**, click on the desired start point to add a discharge time slot. The default duration for a time slot is one hour.
- ii. Click on the time slot to open the floating window. In the field **Power**, specify the desired power level you want the battery to discharging at during this time slot.



- iii. On the timeline **Charge**, click on the desired start point to add a charging time slot.
- iv. Click on the time slot to open the floating window. In the field **Power**, specify the desired power level you want the battery to charge at during this time slot.

**step 6** If **Weekdays&Weekends** is selected, click  , to configure battery discharging and forced charging times for weekdays and weekend scenarios separately.

**step 7** To add a seasonal schedule, click **Add** next to the default seasonal schedule.



On the seasonal schedule tab, click  to edit the name of the schedule, or delete it.

**step 8** Click **Save**.

-- End

### 15.2.3 Virtual Power Plant (VPP) Dispatching

In the VPP mode, the energy storage system allows for management of grid-side resources through platforms like iSolarCloud with external API interfaces.

The energy storage system responds dynamically to the commands and operational directives issued by power grid companies and operators.

#### Prerequisites

- The web UI has switched to the energy management scenario.

**step 1** Click **Energy Management** to navigate to the corresponding page.

**step 2** In the drop-down list **Working Mode**, select **VPP**.

**step 3** Click **Save**.

-- End

### 15.2.4 Compulsory Mode

The compulsory mode is mainly used for battery operation and maintenance, enabling the battery to function based on specific charging and discharging settings. After maintenance, restore the system to its original working mode.

#### Prerequisites

- The web UI has switched to the energy management scenario.

**step 1** Click **Energy Management** to navigate to the corresponding page.

**step 2** In the drop-down list **Working Mode**, select **Compulsory Mode**.

**step 3** In the drop-down list **Charging/Discharging Command**, select the required action.

- **Charge:** The battery charges at the set power level until it is fully charged.
- **Discharge:** The battery discharges at the set power level until it is fully discharged.
- **Stop:** Manually stop the battery from charging or discharging. The batteries will enter the standby mode.

**step 4** If **Charge** or **Discharge** is selected, in the field **Charging/Discharging Power**, specify the desired power level for charging or discharging.

**step 5** Click **Save**.

-- End

## 15.3 Configuring Cascaded Scheduling



Cascaded Scheduling is available on LOGGER-SV300.001.00.P044 or later.

**step 1** Navigate to **Device Maintenance > Device List**.

**step 2** Click **Add Device** and set **Device Type** to SUNGROW Logger in the pop-up window.

**step 3** Select the status of host-client scheduling control in **Cascaded Scheduling**.

- **Enable:** Enable Cascaded Scheduling, where the client Logger1000 is subject to the control by the host Logger1000. Multiple Logger1000 devices are cascaded and the current Logger1000 serves as the host.



In Cascaded Scheduling mode, to use a client Logger1000 device for energy management or power regulation, first log in to the host Logger1000 in the system and disable Cascaded Scheduling for that client.

- **Disable:** Disable Cascaded Scheduling, where the client Logger1000 is not controlled by the host Logger1000. All inverters are connected to the same Logger1000 device and the inverters must all be string inverters or central inverters.

-- End

# 16 Maintaining the Data Logger

## 16.1 Setting System Time

Ensure the Logger1000's system time is accurate. Both manual and automatic time synchronization methods are supported.



During commissioning, it is recommended to synchronize with the local machine time using **User Define** . If the Logger1000 is connected to the Internet, prioritize time synchronization with iSolarCloud. If iSolarCloud is not accessible, use NTP (Network Time Protocol) for time synchronization.

**step 1** Click **System > System Time** to navigate to the corresponding page.

**step 2** In the drop-down list **Clock Source**, select the preferred time synchronization method.

The following time synchronization methods are supported:

- **User Define**: Manually set the current time and time zone of the Logger1000.
- **NTP**: Synchronize the time of the Logger1000 with the server's time.
- **IEC104**: Synchronize the clock using the IEC 104 communication protocol.
- **iSolarCloud**: Synchronize the Logger1000's time with iSolarCloud.
- **Modbus-TCP**: Synchronize the clock over TCP/IP networks using the MODBUS-TCP protocol.

**step 3** Click **Save**.

**step 4** Optional: Check **Inverter Timing** to synchronize the Logger1000's time with that of connected SUNGROW inverters.

-- End

## 16.2 Enabling Remote Maintenance

After remote maintenance is enabled, O&M users can access the Web UI through the remote maintenance link and user authentication information.

**step 1** Click **System > Remote Maintenance** to navigate to the corresponding page.

**step 2** In the drop-down list **Remote Maintenance Switch**, select **Enable**.

**step 3** Select the corresponding server.



The server address is associated with the iSolarCloud forwarding Modbus ID. If you need to change it, modify the iSolarCloud server.

**step 4** Click **Save** to open the **Remote Access** dialog box.

**step 5** Enter the login password and click **Confirm**.

A remote maintenance link will be created.

**step 6** Click **Copy Remote Access Information** to save the access information locally.

**step 7** In the field **Email**, enter the desired email address to receive the access information, and click **Send**.

- - End

## 16.3 Updating the Logger1000

You can update the Logger1000's firmware via the Web UI.



- For the required tools and resource files for the update, contact SUNGROW.
- The update package file must be in .zip format.
- For Logger1000 with firmware version P044 or later, in O&M mode, the Web system can be updated to a later version, but reverting to an earlier version is not allowed. To revert to an earlier version, switch to R&D mode first.

**step 1** Click **System > System Maintenance** to navigate to the corresponding page.

**step 2** Click **System Update**, in the dialog **Select a Firmware File**, select an update method.

The following update methods are supported:

- **Local Update Package:** In the resource window, choose the firmware file and verify the matching devices.
- **Online Update Package:** Obtain the firmware package through the iConfig tool and proceed with the update.
- **iSolarCloud Upgrade Package:** Use the online firmware package available through iSolarCloud to update the device.

**step 3** Follow the on-screen instructions to complete the update process.

A confirmation dialog box appears. Upon confirmation, the Logger1000 will automatically restart to apply the firmware update. The new firmware will take effect after a reboot.

- - End

## 16.4 Restarting Logger1000

**step 1** Click **System > System Maintenance** to navigate to the corresponding page.

**step 2** Click **Rebooting**.

**step 3** In the prompt, click **Confirm**.

-- End

## 16.5 Restoring to the Factory Settings

This will restore all modified Logger1000 settings to the factory state.

**step 1** Click **System > System Maintenance** to navigate to the corresponding page.

**step 2** Click **Reset All Settings**.

**step 3** In the prompt, click **Confirm** to restore all parameters to the default settings.

-- End

## 16.6 Viewing the Firmware Version

Check the firmware information of the Logger1000.

**step 1** Click **About** to navigate to the corresponding page.

**step 2** Under **Version**, click the corresponding to **Value** for five times to view the following information.

Firmware Information	
Name	Value
Device S/N	A2261658059
Version	M_Logger1000_V01_V01_A

The firmware version of the Logger1000 is identified by Application Software Version, formatted as "LOGGER-SV300.001.00.P[XXX]". For easier recognition, the firmware version is often shortened and referred to as "P[XXX]."

-- End



To add this Data Logger to iSolarCloud, simply scan the QR code on the page **About** using iSolarCloud App. The App will automatically detect the Data Logger's serial number.

## 16.7 Viewing History Operations

Click **History Data > Operation Log** to navigate to the corresponding page. You can review a log of past activities or changes made within the system.

## 16.8 Certificate Management

Users can import HTTPS, IEC104, and Modbus TCP certificates for the Logger1000 and view details about the IEC104 and Modbus TCP certificates.



This feature is available on LOGGER-SV300.001.00.P044 or later.

### Pre-configured Certificate Risk Statement

Certificates are pre-configured on SUNGROW devices during the manufacturing process as their necessary identity credentials. Regarding the use of these pre-configured certificates, please note the following:

- Pre-configured certificates are only used to establish an initial secure channel for the device to access the customer network during the deployment process. SUNGROW does not promise or guarantee the security of the pre-configured certificates.
- SUNGROW does not promise or guarantee the security of the pre-configured certificates when used in services. It is recommended that users replace them with their own secure certificates.
- The validity period for the HTTPS certificate pre-configured by SUNGROW is 25 years, while the validity period for the IEC104 and Modbus TCP certificates is 1 year. Once a pre-configured certificate expires, the related service will be interrupted.
- If users choose to use their own certificates, it is recommended that they properly manage the certificate lifecycle. Certificates with a short validity period are recommended to ensure security.

### Steps

**step 1** Navigate to **System > Certificate Management**. Three types of certificate are available here: HTTPS, IEC104, and Modbus TCP.

**step 2** To import an HTTPS certificate, for example, click **Import Certificate**. Then, in the pop-up window, click  to select the .crt certificate file and the .key private key file.

- step 3** Click **Confirm**. Once the files are successfully imported, a prompt will appear asking whether to restart the system.
- step 4** Click **Certificate Information** on the **IEC104 Certificate** or **Modbus TCP Certificate** tab page to view the detailed information about the certificate, including version, S/N, signature algorithm, validity period, public key, issuer, and user.

**-- End**

# 17 User Management

The system administrator can create and manage O&M user accounts, reset account passwords, set account protection and session security parameters, and enable the developer debugging mode.

## Prerequisites

- Firmware version of Logger1000: P035 or above. See [16.6 Viewing the Firmware Version](#).
- The user has administrator permissions.

## 17.1 User Roles and Permissions

The following roles are provided:

- O&M user
- R&D user
- System administrator



The R&D user account is reserved only for SUNGROW's technical support engineers.

Menu permissions	User role	
	O&M user	System administrator
View real-time data of the power plant	✓	×
Configure serial ports of the Data Logger	✓	×
Configure data communication and transfer protocols	✓	×
Device Administration	✓	×
Configure device parameters	✓	×
Export data	✓	×
Control active and reactive power	✓	×
Switch the operating modes of the Data Logger	✓	×
Maintain the Data Logger	✓	×
View available accounts of all O&M users	×	✓
Create or delete O&M user accounts	×	✓
Reset account password	×	✓



Menu permissions	User role	
	O&M user	System administrator
Set account security parameters	×	✓
Enable the O&M mode	×	✓

## 17.2 Factory Default Passwords

Username	User role	Initial password
maintain	O&M user	pw1111
administrator	System administrator	pw@111111

## 17.3 Setting Up Administrator Account

The system administrator account must be associated with an email or phone number. This ensures that if you forget your password, it can be reset through verification via your phone or email.

**step 1** Click **Link Account** to navigate to the corresponding page.

**step 2** Enter the necessary contact information.

Depending on the interface language, you can associate the account with the following:

- Email address
- Phone number



If both an email address and phone number are added, the system will prioritize the phone number for verification purposes in the event of password recovery.

**step 3** Click **Save**.

**step 4** Optional: To delete the associated email or phone number from the account, click **Unlink**.

-- End

## 17.4 Creating O&M Users

You can create additional operation and maintenance user accounts to meet the needs of operation and maintenance.

The default O&M user account is "maintain" and it cannot be deleted.

As a system administrator, you can create up to 4 additional O&M user accounts.

### **Username requirements**

- May include uppercase letters, lowercase letters, numbers, and underscores ( \_ )
- Must begin with a letter
- Username length should be between 4 to 16 characters

### **Password requirements**

- Must contain at least three of the following four types of characters: uppercase letters, lowercase letters, numbers, and special characters
- Password length should be between 8 to 32 characters

**step 1** Click **User Management** to navigate to the corresponding page.

**step 2** Click **Add** to open the **Add User** dialog box.

**step 3** Enter the desired username and password.

**step 4** In the drop-down list **Permission**, select **O&M User**.

**step 5** Click **Confirm**.

-- End

## **17.5 Deleting O&M Users**

**step 1** Click **User Management** to navigate to the corresponding page.

**step 2** Locate the user account you intend to remove, and in the action column, click  .

**step 3** In the confirmation pop-up, click **Confirm** to remove the user account.

**step 4** Optional: To remove all user accounts except "maintain", click **Clear Users**

-- End

## **17.6 Resetting Account Password**

### **17.6.1 Resetting O&M Account Password**

**step 1** Click **User Management** to navigate to the corresponding page.

**step 2** Click  to open the **Modify User** dialog box.

**step 3** Reset password.

**step 4** Click **Confirm**.

-- End

## 17.6.2 Resetting Administrator Account Password

**step 1** Open the Logger1000's login page.

**step 2** Enter the username: **administrator**.

**step 3** Click **Forgot Password** to open the **Modify Password** dialog box.

**step 4** Enter the private key.

You can receive the private key via the email or phone number associated with the administrator account.



If the administrator account is not associated with an email or a phone number, contact SUNGROW Customer Service.

**step 5** Enter the new password and confirm.

**step 6** Click **Confirm**.

-- End

## 17.7 Setting Account Security Parameters

To enhance account security, you can configure the related parameters to control login behavior and session validity.

**step 1** Click **Login Management** to navigate to the corresponding page.

**step 2** Modify account security related parameters:

The following parameters can be configured:

- **Number of Illegal Visits:** Specify how many times a user can attempt to log in. An account will be auto-locked if the number of incorrect password attempts exceeds this limit. (Range: 3-6; Default: 6)
- **Login Timeout:** Specify a duration of inactivity after which the system will automatically log the user out, requiring re-authentication. (Range: 10-30; Default: 10)
- **User Lock Time:** Set the duration before a locked account, due to consecutive failed sign-in attempts, is automatically unlocked. (Range: 10-30; Default: 10)

**step 3** Click **Save**.

-- End

## 17.8 Enabling the O&M Mode

To permit the R&D user to access the Web UI, the administrator needs to activate **R&D Debugging**.

**step 1** Click **R&D Management** to navigate to the corresponding page.

**step 2** Turn on the switch.

The switch will automatically turn off after being turned on continuously for 24 hours. By default, this switch is turned off.

- - End

# 18 Troubleshooting

**⚠ DANGER**

Improper grounding may cause fatal electric shock!

**⚠ DANGER**

Damaged product or system failures may cause electric shock or fire!

- Visually inspect the device for damage or other hazards before troubleshooting.
- Ensure all connections are secure.

**NOTICE**

Be sure to restart the device only after the fault has been fully resolved to prevent fault expansion or device damage.

Problem	Causes and Corrective Measures
All indicators remain off	<b>The power supply terminal of the Logger1000 has no power connection.</b> Ensure the Logger1000 is connected to the power box.
	<b>Power supply failure</b> Check power supply and input voltage with a multimeter.
	<b>Logger1000 failure</b> Replace the power supply if needed.
Not all devices are being detected	<b>The RS485 port is not connected to any devices or the connection cable is loose or connected reversely.</b> Check and secure RS485 connections.
	<b>Incorrect RS485 communication parameters</b> Verify RS485 serial parameters for baud rate and communication address.
	<b>Devices like meteo station or energy meter not manually added</b> Manually add the devices,
	<b>Mismatched device address</b> Verify and correct the device address settings.

Problem	Causes and Corrective Measures
	<p><b>Device malfunction</b> Check the device operation status.</p>
	<p><b>Loose or disconnected communication cable</b> Check and secure cable connections.</p>
Device disconnected	<p><b>Device malfunction</b> Power on the device and confirm connections.</p>
	<p><b>Device removed or configuration changed</b></p> <ul style="list-style-type: none"> <li>• Rescan or manually add replaced devices.</li> <li>• Delete removed devices on the Web UI.</li> </ul>
	<p><b>Logger1000 cannot communicate with the backend</b> Check whether the Logger1000 is correctly connected to the PC or router.</p>
Cannot communicate with the backend	<p><b>Incorrect data forwarding configuration</b> Verify network settings.</p>
	<p><b>The forwarding protocol configuration is incorrect</b> Check forwarding protocol settings.</p>



If these troubleshooting steps don't resolve your issues, please contact SUNGROW.

# 19 Routine Maintenance

To ensure the normal operation and lifespan of the Logger1000, it needs to be maintained regularly.

## 19.1 Safety Notes

### NOTICE

**Improper maintenance may cause product damage!**

- **During operation and maintenance, if product replacement is involved, contact SUNGROW.**
- **If it involves replacement parts, ensure to use original parts sold or recommended by SUNGROW.**

### NOTICE

**Losses caused by maintenance not in accordance with this manual are not covered by the warranty.**

## 19.2 Maintenance Items

### NOTICE

**Do not perform maintenance beyond the manual's scope to avoid electric shock. If necessary, contact SUNGROW for maintenance. Otherwise, the losses caused are not covered by the warranty.**



Maintain maintenance logs to extend product lifespan.

Item	Method
Working environment	<ul style="list-style-type: none"><li>• Ensure no strong electromagnetic interference devices are nearby.</li><li>• Keep heat sources away from the product.</li><li>• Avoid placing corrosive substances near the product.</li></ul>

Item	Method
Hardware	<ul style="list-style-type: none"> <li>• Confirm normal power supply voltage.</li> <li>• Check for secure circuit connections.</li> <li>• Verify reliable grounding.</li> </ul>
System cleaning	<ul style="list-style-type: none"> <li>• Confirm that the enclosure, circuit board and other components are clean.</li> <li>• Ensure heat dissipation holes are free from dust and blockages.</li> </ul>
Terminal and cable connection	<ul style="list-style-type: none"> <li>• Tighten loose control terminal screws.</li> <li>• Check for rust on wiring copper bars or screws.</li> <li>• Visually inspect device terminals and wiring layout.</li> </ul>
Software	<ul style="list-style-type: none"> <li>• Verify the device's communication status.</li> <li>• Verify the parameter settings.</li> <li>• Verify the firmware version.</li> </ul>

### 19.3 Module-Level Rapid Shutdown

Module-level rapid shutdown ensures that photovoltaic (PV) modules can be quickly and safely deactivated during maintenance or emergencies, enhancing the overall system safety.

#### Prerequisites

- Optimizers or shutdown devices with rapid shutdown capabilities are already installed in the current PV arrays.
- Firmware version of Logger1000: P042 or above.



**step 1** Connect the Logger1000 and the rapid shutdown button through any DI port. See [5.11 Connecting to the Emergency Stop Device](#).



If DI5 is already used for an inverter emergency stop device, connect the rapid shutdown button to a different DI port. However, if you use DI5 for the rapid shutdown button, no other DI ports can be used for an additional inverter emergency stop device.

**step 2** Log into the Logger1000's web UI and configure the DI port settings. See [8.6 Digital Inputs \(DI\) Port](#).

**step 3** Press the rapid shutdown button to activate the rapid shutdown feature.

-- End

## 19.4 Replacing Logger1000

If it becomes necessary to replace the Logger1000 due to reasons such as power station upgrades, ensure to reconfigure the settings on the Web UI after completing the hardware replacement to maintain normal device communication.

### Prerequisites

- The inverters connected to the original Logger1000 are operating normally.
- The new Logger1000 intended for replacement has been reset to factory settings.
- Firmware version of Logger1000: P042 or above.

### DANGER

**If the Logger1000 is in the COM100D/E, you must first disconnect the power to the COM100D/E before proceeding with the replacement.**

**step 1** Turn off the power to the Logger1000.

**step 2** Disconnect all cables connected to the Logger1000.

**step 3** Remove the Logger1000 and install the new one in the same location. See [4.4 Mounting the Data Logger](#).

**step 4** Reconnect the wiring according to the original Logger1000's device connection setup. See [5 Electrical Connection](#).

**step 5** Restore power to the Logger1000.

**step 6** Log in to the Logger1000's Web UI as an O&M user.

**step 7** Follow the setup wizard to configure the network and ensure stable communication with the iSolarCloud. See [7.5 Initial Configuration Using the Setup Wizard](#).

**step 8** Navigate to the page **Device > Device List** to re-add inverters.

**step 9** Modify the inverter addresses.

- i. On the page **Device List**, click  to open the dialog box **Edit Device**.
- ii. Update the inverter device information to ensure the forwarding address matches the previous one.
- iii. Click **Save..**

**step 10** Log in to the iSolarCloud App, and locate the power station initially created with the original Logger1000 to complete the device replacement. For detailed instructions, see iSolarCloud App User Manual.

**-- End**

## 20 Appendix

### 20.1 Technical Data

Logger1000	
<b>Communication</b>	
Max. number of devices	≤30
<b>Communication ports</b>	
RS485 interface	3
Ethernet	1 x RJ45, 10/100/1000Mbps
Digital input	5, Max. 24VDC
Analog input	4, support 4 ~ 20mA or 0 ~ 10VDC
<b>Wireless Communication</b>	
4G Communication	LTE(FDD): B1, B3, B5, B8
	LTE(FDD): B38, B39, B40, B41
	TD-SCDMA: B34, B39
	CDMA: BC0
	GSM: 900/1800 MHz
WLAN Communication	802.11 b/g/n/ac; HT20/40/80MHz; 2.4GHz/5GHz
<b>Power Supply</b>	
DC input	24VDC, max. current: 1.2A
DC output	24VDC, 0.5A
Power consumption	<10W
<b>Ambient Conditions</b>	
Operating temperature	-30°C ~ +60°C
Storage temperature	-40°C ~ +70°C
Operating humidity	≤ 95%, no condensation
Elevation	≤4000m
IP rating	IP20
<b>Mechanical Parameters</b>	
Dimensions (W x H x D)	200 x 110 x 60 mm
Weight	500 g
Mounting method	Top-hat rail mounting/ wall mounting
<b>General Parameter</b>	
Support for software updates	2 years

## 20.2 Cable Routing Requirements

Cables used in the system generally include power cables and communication cables.

### NOTICE

**Each type of cable should be routed in separate trenches to prevent interference. Consider the length and direction of the cables to avoid electromagnetic interference caused by transient changes in output voltage.**

- The length of communication cables should be kept as short as possible to minimize potential interference.
- The communication cables should be laid as close to the ground or support structures (such as support beams, steel channels, metal rails) as possible for stability and to reduce interference.
- Power and communication cables should be routed separately when possible to avoid interference with communication signals.
- If power and communication cables must cross, they should form a 90-degree angle, and the distance between them can be appropriately reduced.
- A minimum separation of 200mm should be maintained between power and communication cables wherever possible.
- When shielded communication cables run parallel to power cables, maintain a minimum spatial distance between them as follows.

**table 20-1** The minimum distances between shielded communication cables and power cables

Parallel cable length (m)	Min. distance (m)
200	0.3
300	0.5
500	1.2

## 20.3 Quality Assurance

If product faults arise within the warranty period, SUNGROW will offer complimentary repairs or replace the product with a new equivalent model at no additional cost.

### Evidence

To be eligible for warranty service during the warranty period, customers must provide the original product purchase invoice showing the date of purchase. Additionally, the product's trademark must be intact and clearly visible. SUNGROW reserves the right to decline

warranty service if these conditions are not met. The software update guarantee for this product expires on December 30, 2035.

### **Conditions**

- Products deemed unqualified for use will be reclaimed and disposed of, or recycled by SUNGROW in accordance with environmental regulations.
- Customers are required to grant SUNGROW a reasonable timeframe to perform repairs on the faulty device.

### **Exclusion of Liability**

SUNGROW may refuse warranty service under the following circumstances:

- The complete unit or components have exceeded the free warranty period.
- Any damage sustained during the transportation of the device.
- Device malfunctions or damage caused by the use of non-standard or non-company parts or software.
- Device malfunctions or damage resulting from improper installation, modification, or use.
- Damage caused by unforeseen natural events.
- Device malfunctions or damage due to operations conducted by service organizations or individuals not affiliated with SUNGROW.
- Issues arising from installation and use beyond the scope prescribed in relevant international standards.
- Damage caused by unforeseen natural events.

Should a product failure arise from the above conditions, and the customer requests repairs, the company's service organization may conduct an assessment and provide a paid repair service.

## **20.4 Contact Information**

If you still cannot resolve the issue or have questions after consulting this manual, please contact SUNGROW. For more efficient service, please provide the following information:

- Model of the device
- Serial number of the device
- Manufacturer and model information for upstream and downstream equipment
- Fault code/name
- Brief description of the problem

For detailed information, see <https://www.sungrowpower.com/headquarter.html>

**SUNGROW**

Sungrow Power Supply Co., Ltd.  
[www.sungrowpower.com](http://www.sungrowpower.com)